



LARS LAJ®

PLAY - SKATE - SPORT - PARK

LARS LAJ[®] PLAYGROUNDS

Originating in Denmark, Lars Laj - with almost 40 years of experience in play, sport, skate and outdoor furniture equipment - is a well established manufacturer, that delivers best quality products world wide. We care for every detail, from a single playground element to a wide variety of equipment for all functions.

Proven manufacturing techniques, combined with the constant technological development and the use of the highest quality materials place our company among the best producers around world. We have representative offices in many countries in Europe, and our playgrounds can be found in locations like Thailand and Korea. Our designs are durable, aesthetic and can provide fun for years and years.

Lars Laj playgrounds have certificates of compliance with the European norm EN 1176, and the safety surfaces are certified according to EN 1177. In terms of compliance with the EN 1176 our production site is inspected yearly by the German certification unit - TÜV.

We strive to fulfill the modern, holistic approach to the play area design: fun, safety, functionality, aesthetics, innovation and serving the most important purpose: bringing people together!

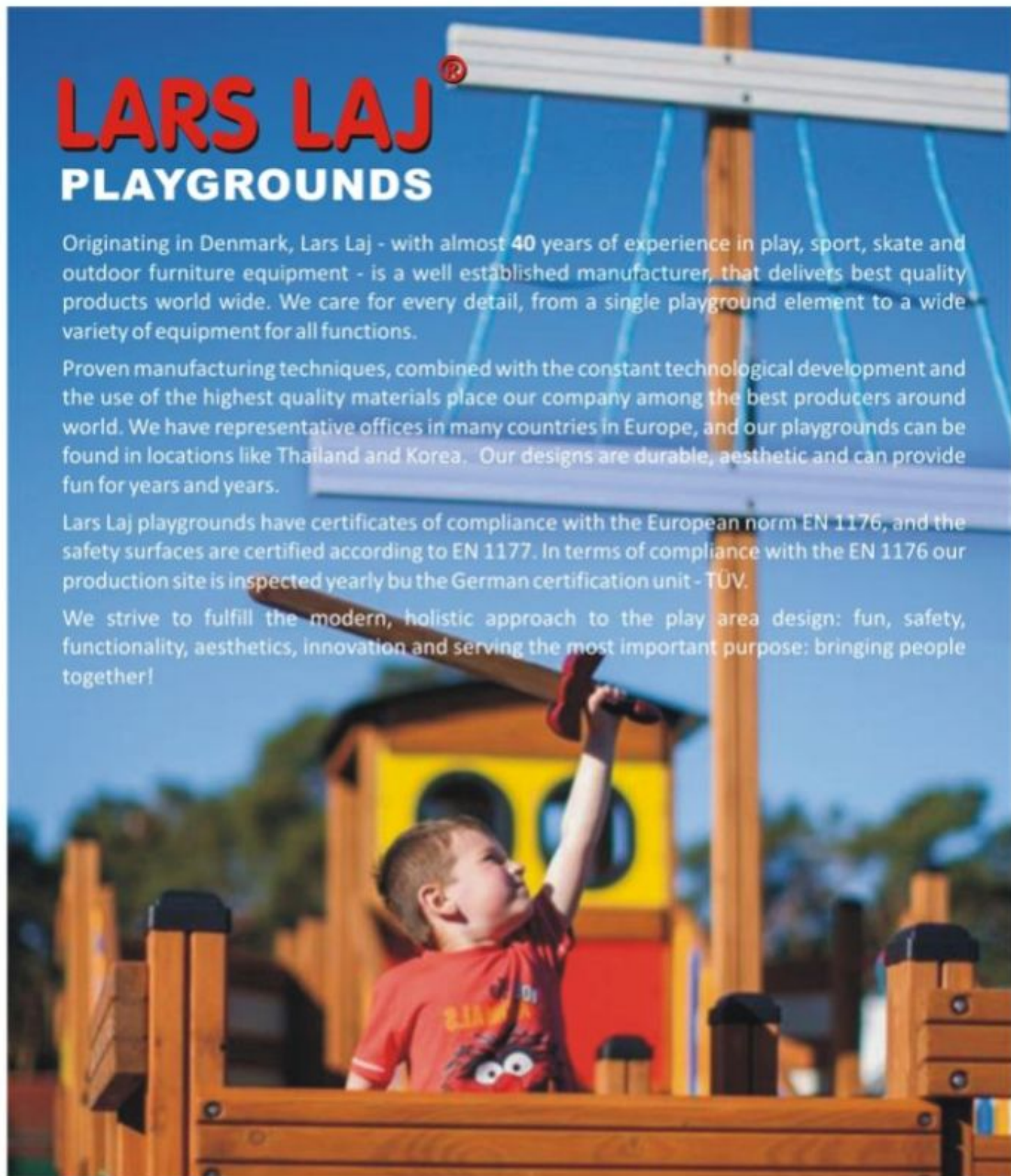

INDEX

	DISCOVERY	1-8 years		8- 27
	SWINGS			28- 39
	SAND & WATER PLAY	1-8 years		40- 45
	CLASSIC NATURE	1-14 years		46- 59
	PIONEER	3-14 years		60- 83
	MODERN NATURE	1-14 years		84- 87
	DREAMWORLD	1-14 years		88- 89
	NATURE	1-14 years		90-105
	WONDERLAND	1-8 years		106-107
	ATLANTIS	1-14 years		108-113
	STAND ALONE	3+ years		114-121
	SOLARIS	3-14 years		122-123
	STREET SPORT			124-137
	SKATE			138-145
	OUTDOOR FITNESS			146-163
	OUTDOOR FURNITURE			164-187
	SUNSHADES			188-189
	SAFETY SURFACES		190-191	



SYMBOLS

Catalog number

PRODUCT NAME



Age

∅ 90

Diameter



Total height



Color



Dimensions

W2W
METAL

Wood2wood

Steel foundation



All - Access



Seat height



Critical fall height

0-50 cm: Safety surface not required

0-100 cm: Sand, bark, grass, grass mats, artificial grass, rubber tiles, wetpour

over 100 cm: Sand, grass mats, artificial grass, rubber tiles, wetpour

Dimensions

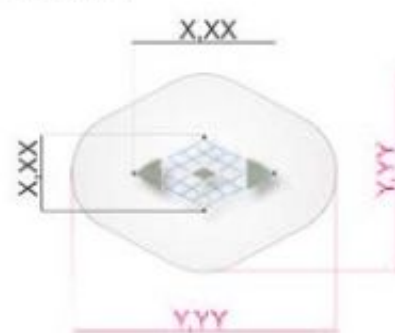

1:200
Scale

Safety zone

Design and prices may be changed due to constant updating and improvement of products.
We accept no liability for any printing errors.



CERTIFICATION

Lars Laj considers safety and quality as our first priority. Our playground system has been designed according to the European standard EN 1176.

The articles have additionally been individually certified, tested and approved by TÜV in Germany, according to the norm DIN EN 1176. TÜV controls that products are designed according to the rules in the EN 1176, and they evaluate that the chosen materials and components realistically offer a lifetime of 15 years for the whole play unit. Over and above individual play item certification, there is minimum 1 yearly factory inspection confirming that the manufacturer assures that each individual product/ component matches the certified products. When special designs and projects according to client's wishes - are required our designers' work according to the EN 1176 rule.



TRADE ASSOCIATIONS

As a socially responsible company Lars Laj is a proud partner of all the major playground industry organisations. We are always on the children's side, as a supporter of UNICEF on their mission to provide long-term humanitarian and developmental assistance to children and mothers in developing countries.



- Lars Laj is a member of FEPI, the European trade association for playgrounds.
See more at www.fepi-play.org

- Lars Laj is a member of P.I.L., the Danish association for playground equipment.
See more at www.pil-dk.dk



GUARANTEE

We are proud to say that our play equipment is built without compromising on safety, quality, and materials. This allows us to offer the highest warranty conditions given in the industry ranging from 5 years to 10 years.

PLAY SYSTEM

Our play system can be designed according to your needs. With our modular playground system we can find the solutions that will work for you. Our experienced custom design department can create truly innovative playgrounds for public parks, schools, natural habitats and other any projects large or small. Extensive knowledge of all relevant guidelines and safety rules, we are able to combine items of equipment fitted for special needs or alterations if required.



DESIGN LAB

At Lars Laj we are always open to new and inspiring ideas. We think outside the box. That is why we have created our own "DESIGN LAB". It consist of a team of conceptual work orientated designers that are working on new and futuristic solutions and cooperate with architecture ateliers from other countries.

If the standard offer just isn't enough for Your imagination to fly and You have a cutting edge idea – contact us. Together we can make it happen!



Climbing village - Copenhagen, Denmark



Carlsberg Spring Platforms, Copenhagen, Denmark



Stettin/Poland
InsideOut lounge for Helsingborg, Sweden



Copenhagen Airport, Denmark



Spark project - Odense, Denmark

INSTALLATION

Lars Laj products can be delivered worldwide with or without installation assistance. Deliveries for distant areas can be installed by the client themselves or with help of local installers. Each playground, as well as each particular unit, has its own detailed installation manual, ensuring that important safety aspects will be observed during installation.

LS90 + B90 - set for platform height 90cm - Installation manual



CONSULTATION

We offer plans and drawings for playground propositions free of charge, with no obligation to the customer. During the design process, the Lars Laj team always uses their knowledge and experience to help our clients make the right decision. Our consultants are there to listen and come up with a solution just right for you whether you need an entirely new playground, or would like to update, renew and upgrade an existing project.



"WOOD2WOOD" FOUNDATION SYSTEM



Our original "Wood2Wood" foundation system ensures durability and long life - without compromising on the environment

Advantages:

- Increased durability - only the oak base support is in contact with the ground
- Water resistant
- No soil corrosion problems normally associated with metal base supports
- 10-YEAR WARRANTY on Wood2Wood oak foundations

GALVANISED STEEL FOUNDATION

Our standard playground is supplied with galvanized steel foundations.



The use of top quality materials, such as for example larch wood, colour coat sheets, plastic and rubber, stainless and galvanised steel and steel-covered rope combined with first class production methods give our playgrounds great durability and makes them look inviting for many years.



1

The PE plates that we use in our playgrounds are made in a variety of colors, so you can choose the color set that you like the most. Visit our website to find out more.



2

Wooden posts are delivered with plastic caps safeguarding against weather conditions.



3

The plastic components used in our climbing nets are designed to last. Combined with our use of steel reinforced rope, help safeguarding against vandalism and exceptionally hard use.



Our climbing stones are made of rubber. Their porous surface prevents fingers from slipping.

Our climbing walls are made of 18 and 22 mm thick waterproof plywood, with a thin layer of strong and weather resistant laminated surface.

The metal foundations of the wooden posts should be installed about 57 to 77 cm into the ground and end about 3 cm above the ground level.

A long lasting steel connection - inherently resistant to corrosion.



4



5



6



7

Pyramid roofs are made of colorful UV resistant fiberglass, which is unaffected by weather conditions and requires no service.



8

Our plastic tube tunnels, with a diameter of 630 mm and wall thickness of 12 mm, are almost unbreakable.



9

Our panel sheets have a thickness of 0,5 - 0,8 mm and they are galvanized and covered with plastisol. Owing to that, they have a minimum 20-year lifespan and keep the playground colorful and inviting in its whole lifetime. Furthermore they require absolutely no maintenance.



10

7

8

9

11

12

In our colorful and solid slides we use stainless steel for the sliding surface and polyethylene plate for the sides.

All wooden elements are planed, all edges are rounded and all screws and bolts are either countersunk or covered with plastic caps.

Panel sheets are fastened to the post with special anticorrosive screws with a rubber washer.



10



11



12

DISCOVERY



10851 DIXIE

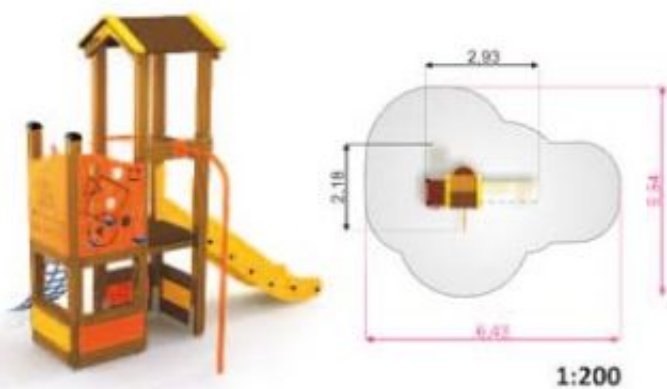

10850 PIXIE



10856 SMART

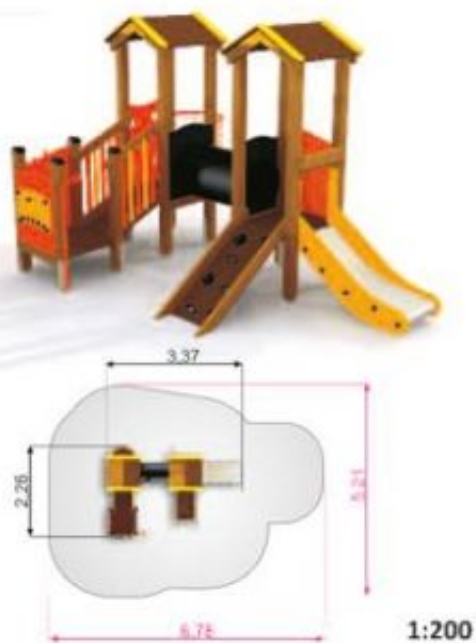

10857 RUBIK

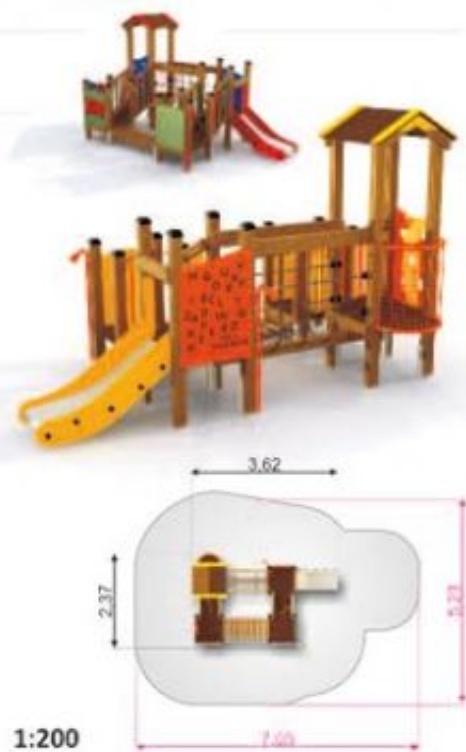

10855 BRAVO

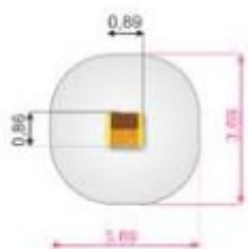

1:200

10852 NEMO

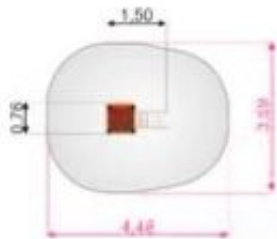

1:200

10853 PI

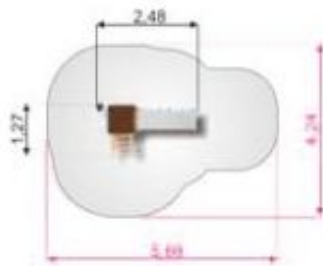

1:200

10854 SIGMA

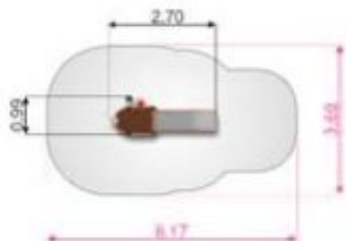
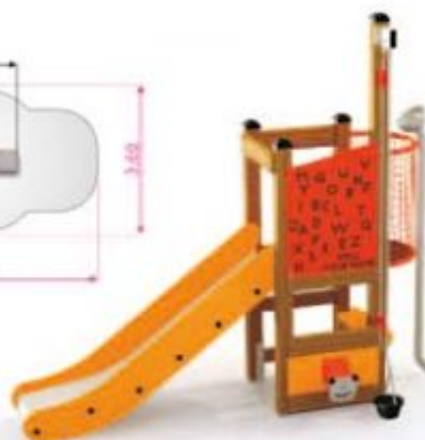

1:200

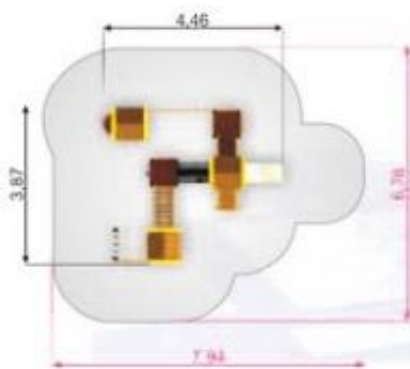

1:200

10770 ALPHA



10766 MINI PLAY

-  1+
-  1,56 m
-  0,55 m
- W2W
METAL
-  8,5 h

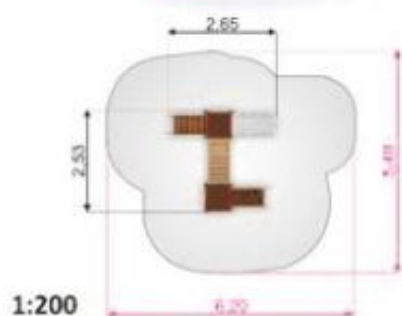

10759 TODDLER TOWER SLIDE

-  3+
-  1,86 m
-  0,90 m
- W2W
METAL
-  3 h

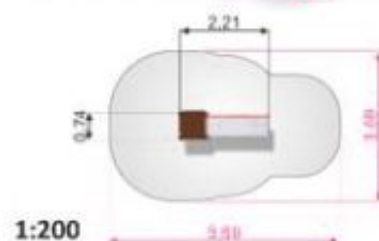

10751 COUNTRY HOUSE

-  3+
-  2,84 m
-  0,90 m
- W2W
METAL
-  8 h

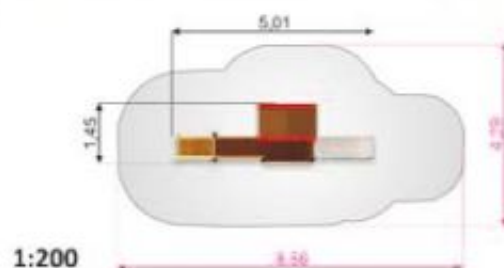

10765 FORTRESS

-  1+
-  2,37 m
-  0,55 m
- W2W
METAL
-  9 h

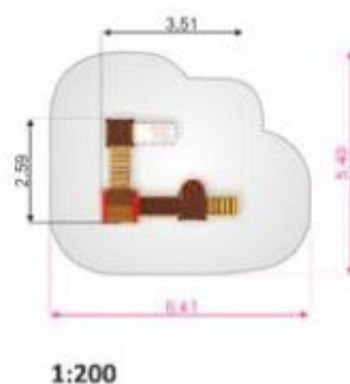



10761
KNIGHT'S CASTLE

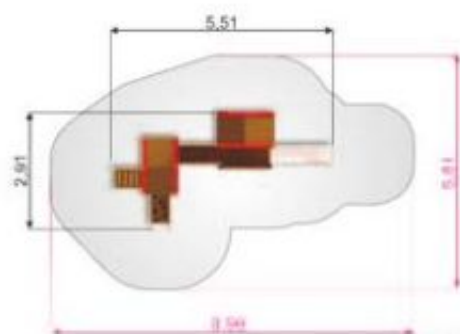

1:200



- 3+
- 2,84 m
- 0,90 m
- W2W
METAL
- 8,5 h

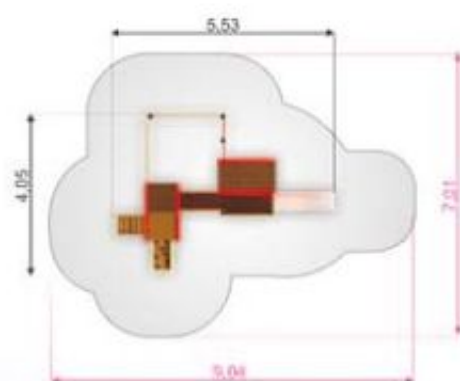

1:200







10762
TOWER

- 3+
- 2,84 m
- 1,45 m
- W2W
METAL
- 9,5 h





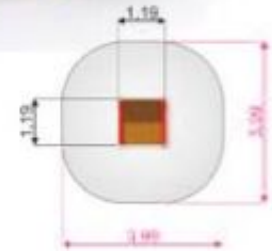

10708
THE PLAYHOUSE

-  1+
-  2,15 m
-  0,30 m
-  W2W
-  2,5 h



1:200



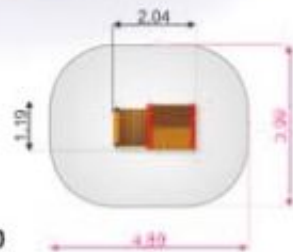

10712
THE VERANDA HOUSE

-  1+
-  2,05 m
-  0,15 m
-  W2W
-  4 h



1:200

10724
THE VILLA



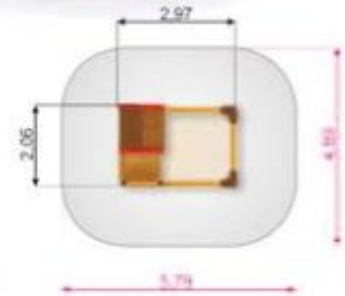



-  1+
-  2,15 m
-  0,38 m
-  W2W
-  6 h



1:200



10720
THE PLAYHOUSE

-  1+
-  2,45 m
-  0,55 m
-  W2W
-  METAL
-  5 h

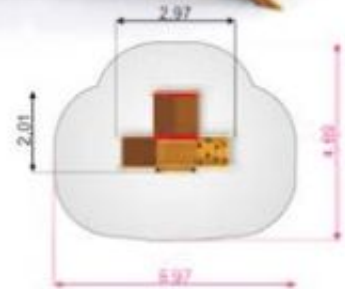

1:200

11283 CLOCK

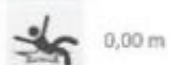

W2W
METAL

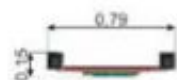

1:50

11282 MEMORY



W2W
METAL

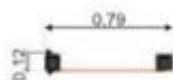

1:50

11281 TIC TAC TOE



W2W
METAL

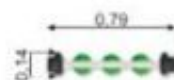

1:50

11285 MEGAPHONE

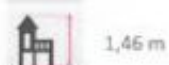

W2W
METAL

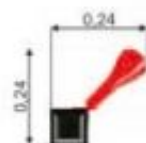

1:20



11400 CAMEL



W2W



3+

1,64 m

0,90 m

2,5 h

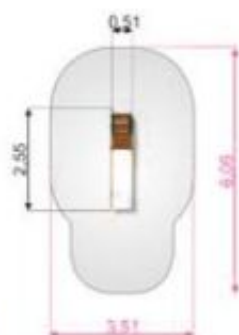

1:200

11404 ELEPHANT



W2W
METAL



3+

3,21 m

1,20 m

5,5 h

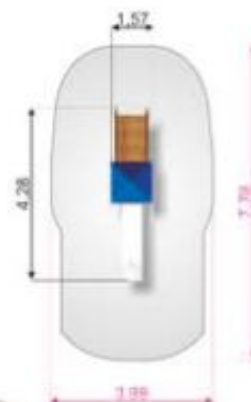

1:200

11255

SEAL

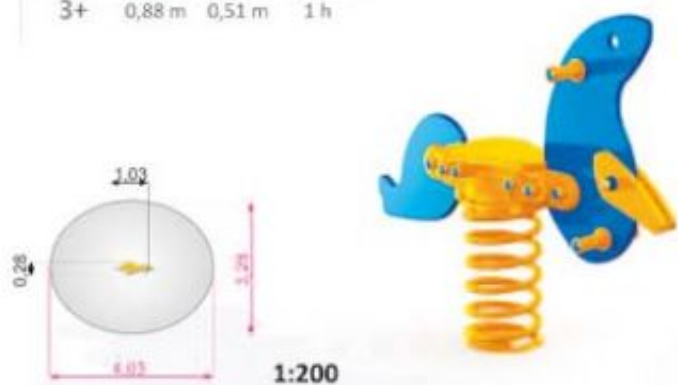

11253

ROOSTER

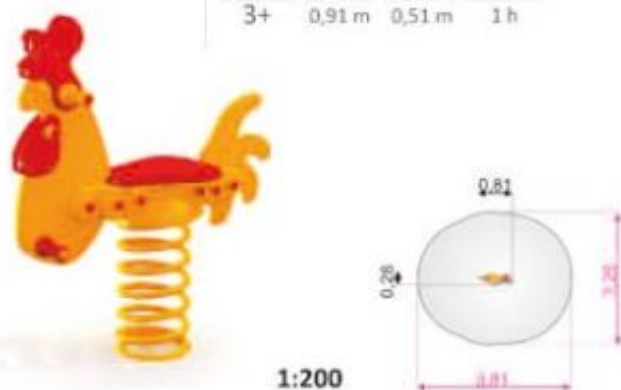

11261

PONY

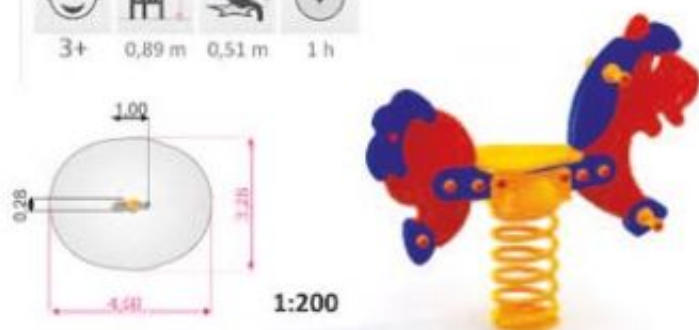

11265

GIRAFFE

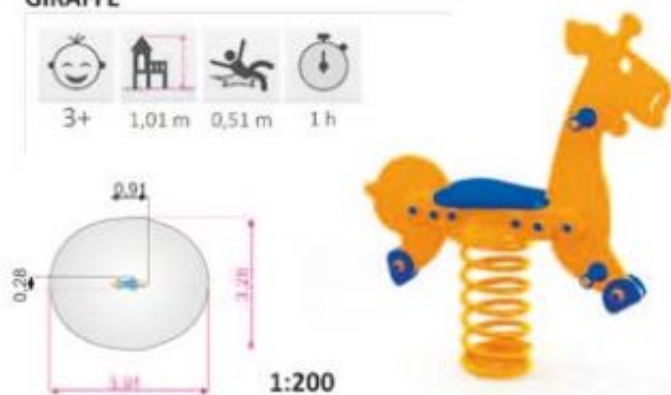

11252

RABBIT

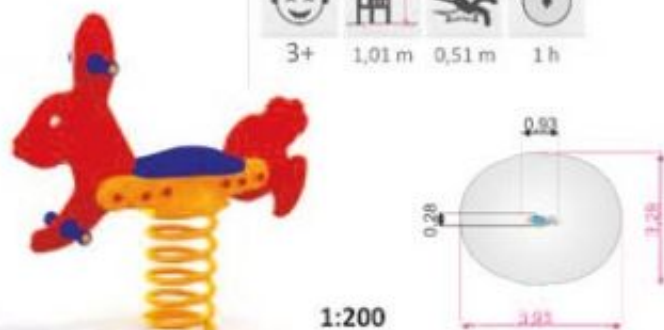

11248

SCOOTER

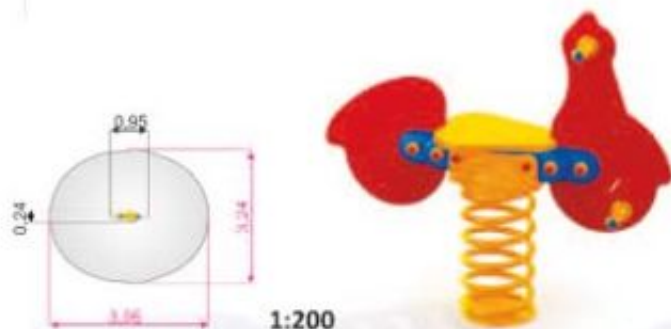

11251

DOGGY

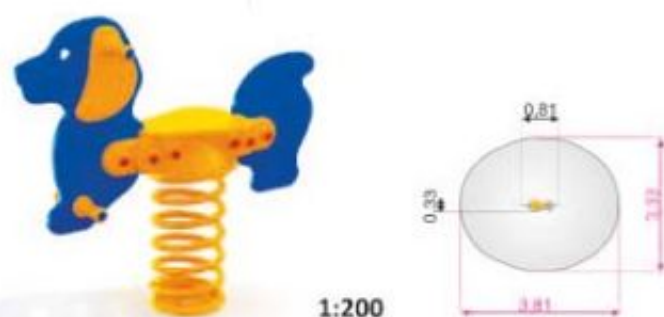

11250
DOG SPRING

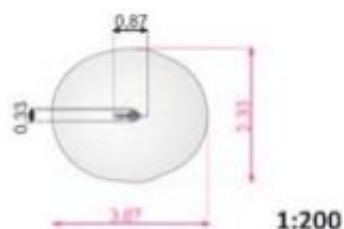
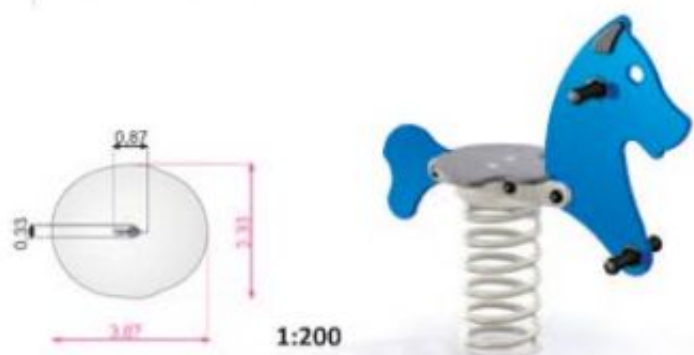

1:200

11254
PONY SPRING

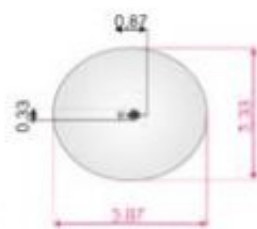

1:200

11256
SEAL SPRING

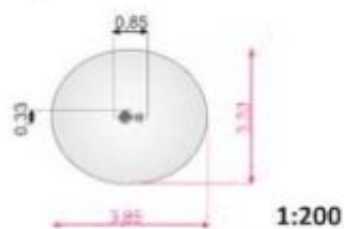

1:200

11257
WALRUS SPRING

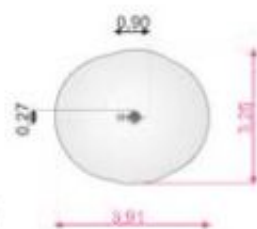

1:200

12221
BIRD SWING

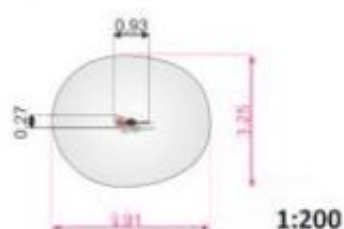

1:200

12220
YACHT

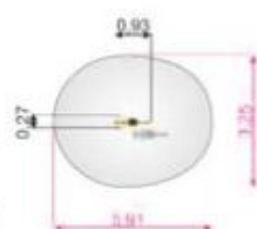

1:200

12165
MINI BALANCE

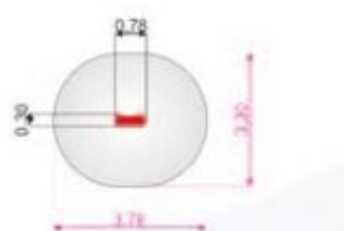



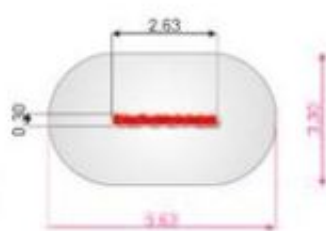

1:200

12166
BALANCE



1:200

17112
TURTLE SPRING

-  2+
-  0,81 m
-  0,50 m
-  1 h

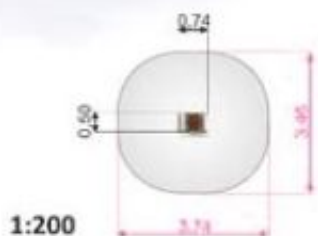



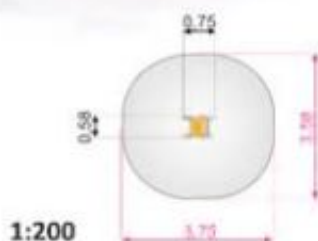

11258
CAR

-  2+
-  0,83 m
-  0,51 m
-  1 h



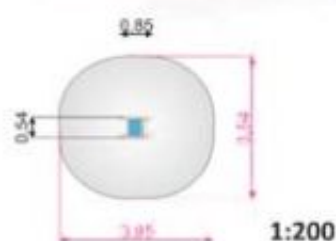

11259
WHALE

- 2+ 
- 0,82 m 
- 0,51 m 
- 1 h 





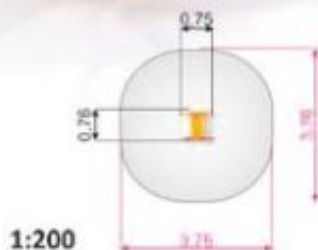

11268
DOUBLE AUTO SPRINGER

-  2+
-  0,83 m
-  0,51 m
-  1,5 h



11275
BULLDOZER

- 2+ 
- 0,83 m 
- 0,51 m 
- 1 h 

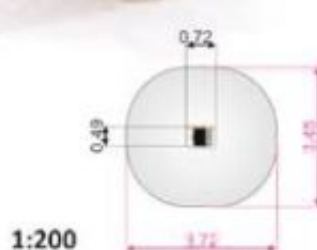

11249

CLOVER



3+



0,58 m



0,66 m



1,5 h

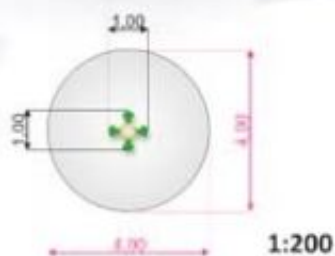

11260

DOUBLE PONY SPRING

3+



0,90 m



0,51 m



2 h

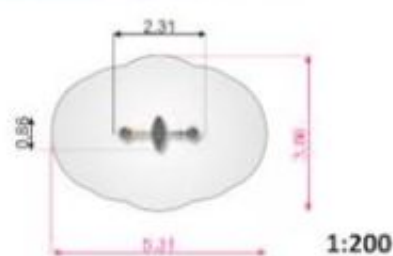

11263

TRIPLE WALRUS SPRING



3+



0,81 m



0,51 m



2 h

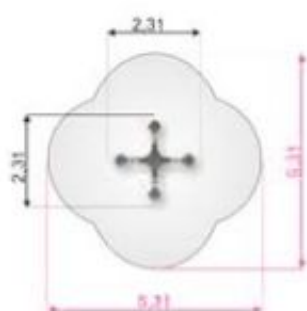
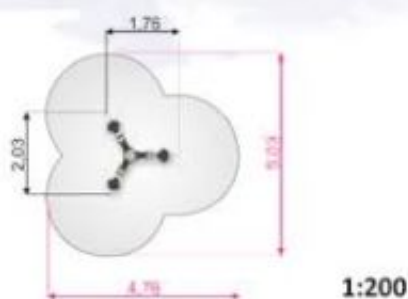

1:200

11264

QUADRO WALRUS - SEAL SPRING

3+



0,81 m



0,51 m



2 h



10738

LOCOMOTIVE

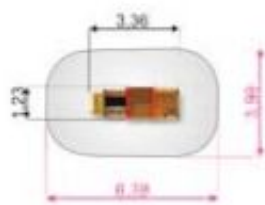

1:300



10736

LOCOMOTIVE WITH SLIDE

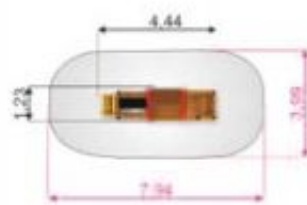

1:300



10742

TRAIN



1:300

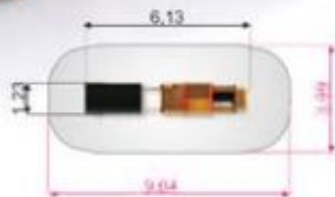

10737

LOCOMOTIVE WITH CARS



1:300

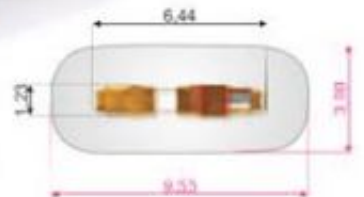

11423
SMALL SHIP

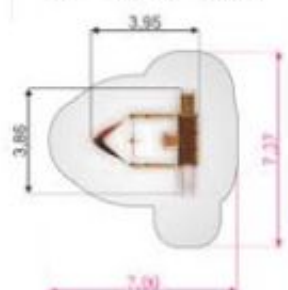

1:300



11424
FISHER BOAT

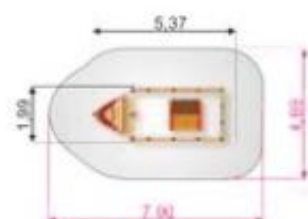

1:300



11425
SHIP

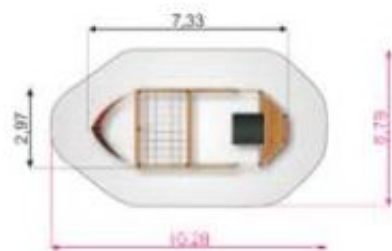

1:300



FARM

11270
COW



11271
SHEEP

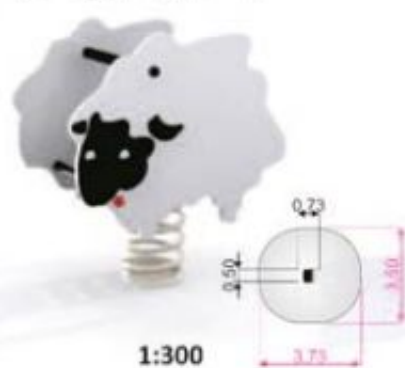

11274
PIGGY

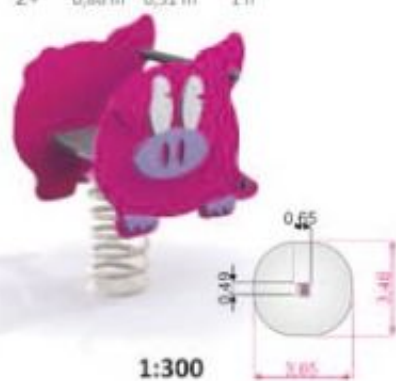

11273
MINI TRACTOR SPRINGER

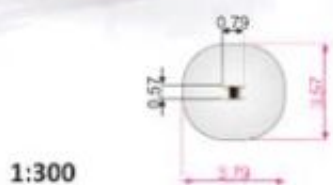

10745
TRAKTOR

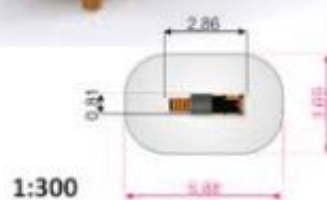

10744
TRAKTOR WITH TRAILER

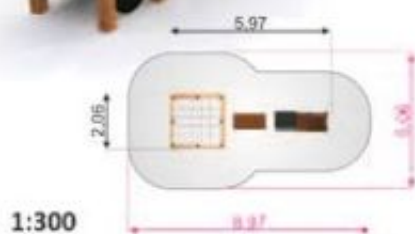

11278
CAR TRAILER

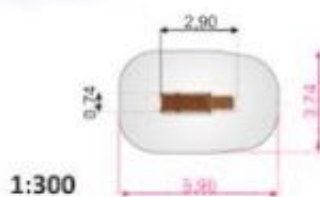

20007-1 VILLA WITH ORCA

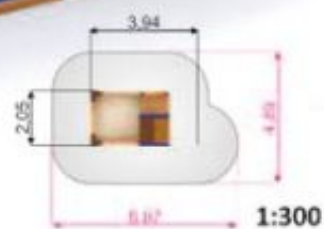

20008-1 SMALL SHIP WITH DOLPHIN

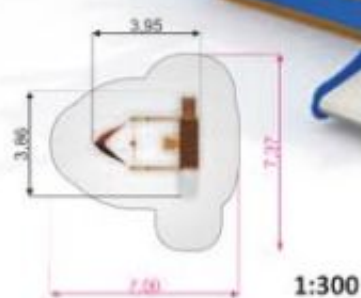

20006 DOLPHIN SLIDE

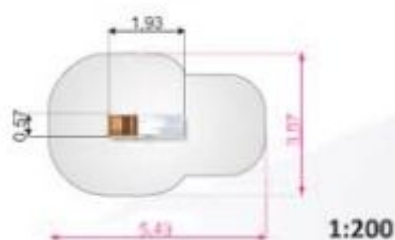

FIRE BRIGADE

10870

FIRE-STATION



3+ 2,61 m 1,75 m 5 h

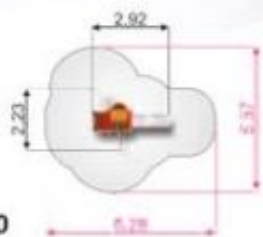

1:300

10875

FIRE BRIGADE CAR



1+ 1,91 m 0,30 m 6,5 h

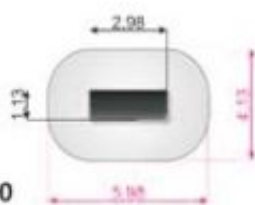

1:300

10890

FIRE BRIGADE TRUCK



1-3 1,11 m 0,21 m 2 h

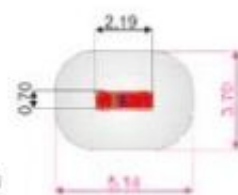

1:300





POLICE

10871

POLICE STATION



3+ 2,61 m 1,90 m 5 h

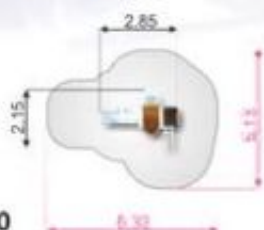

1:300

10876

POLICE TRUCK



1+ 1,91 m 0,30 m 5 h

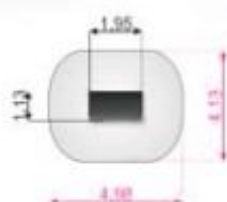

1:300

10891

POLICE CAR



1-3 1,11 m 0,21 m 2 h

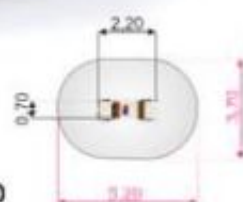

1:300



10892
TAXI

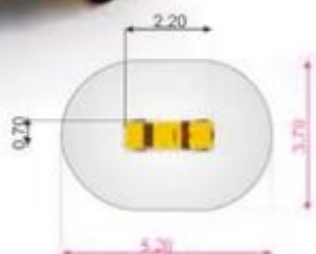

1:200

10746
BUSS

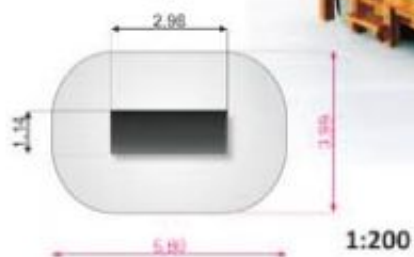

1:200

10893
TRUCK

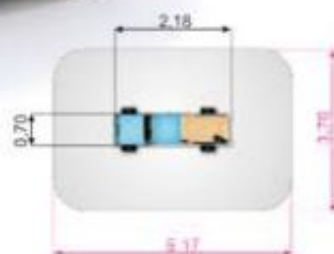

1:200



ALL ACCESSIBLE



10771

BETA - ALL ACCESSIBLE PLAYGROUND

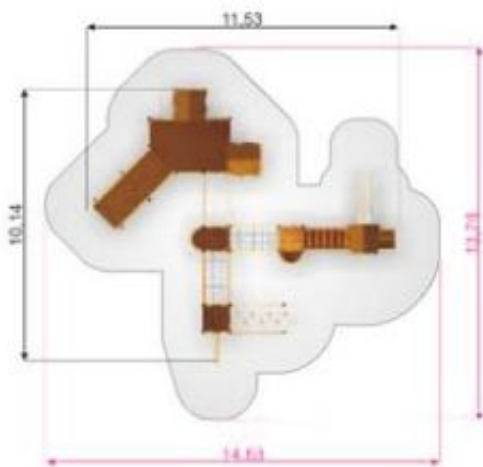

1:300



10858

TRIXIE - ALL ACCESSIBLE PLAYGROUND

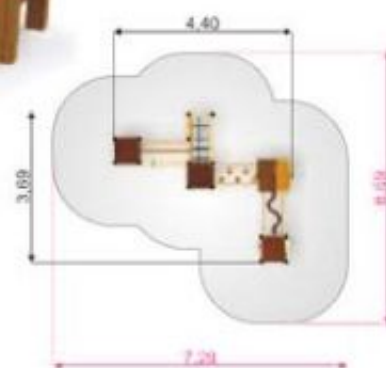

1:200



10727

ALL ACCESSIBLE SANDBOX

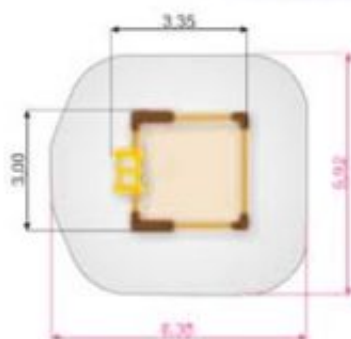

1:200

10769

ALL ACCESSIBLE PLAYGROUND

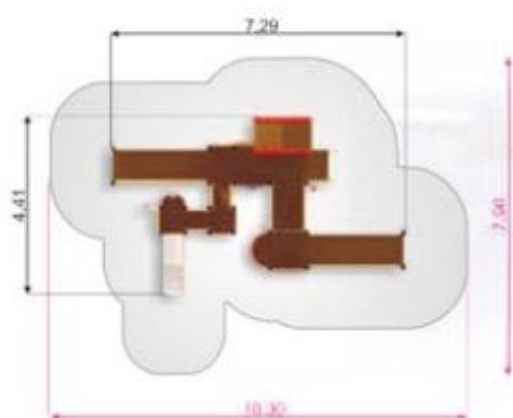

10775

CAMPANILLE - ALL ACCESSIBLE PLAYGROUND

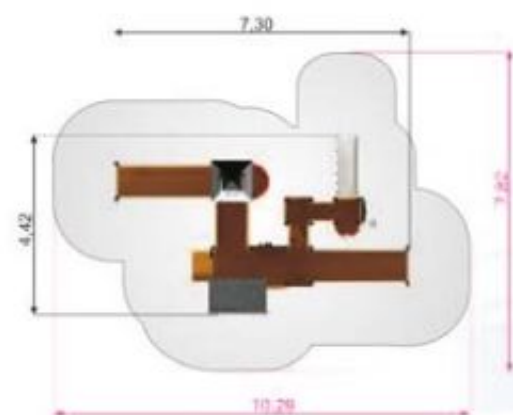

SWINGS



11100 SINGLE SWING

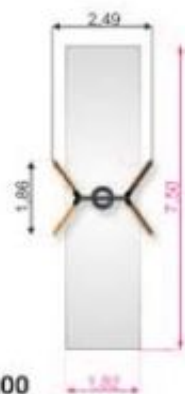

1:200

11101 SAFETY SEAT SWING

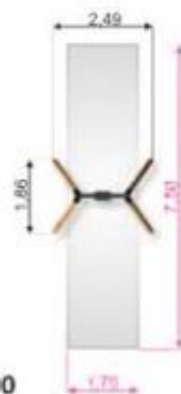

1:200

11102 BABY SWING

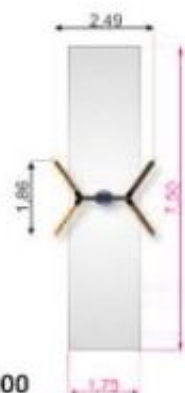

1:200

11104 FLEXI SEAT SWING



1:200

11120
DOUBLE TYRE SWING

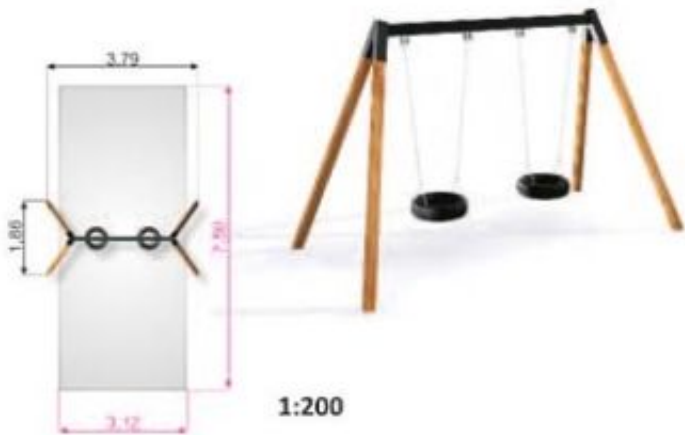

11121
DOUBLE SAFETY SWING



11122
DOUBLE BABY SWING

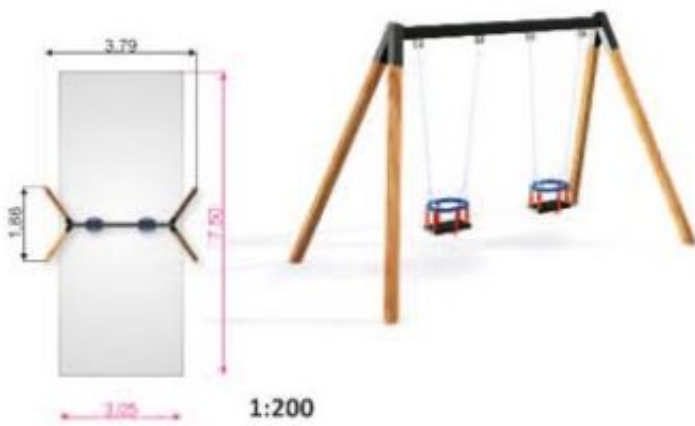

11123
DOUBLE SWING

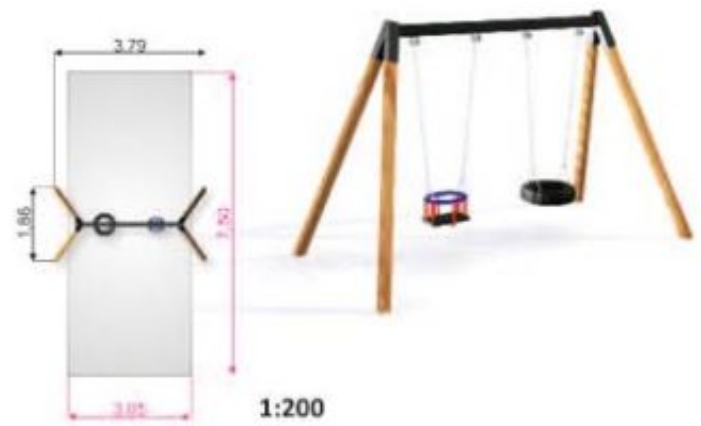

11130
DOUBLE SWING 1+1

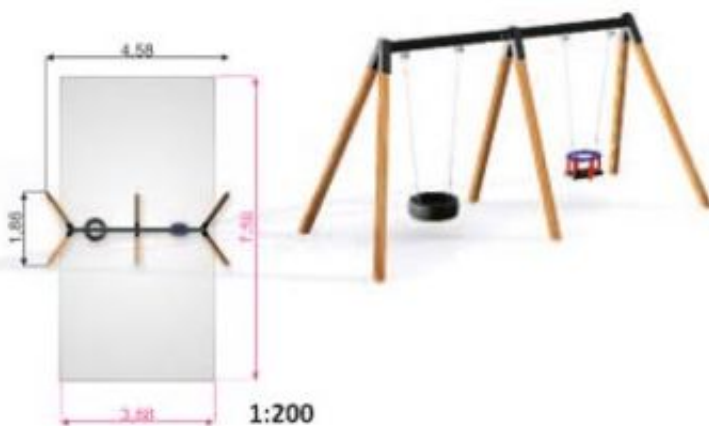

MODIFICATION

11103

SWING (BIRD NEST)



3+



2,35 m



1,35 m

W2W
METAL



2,5 h



ø 90



ø 120

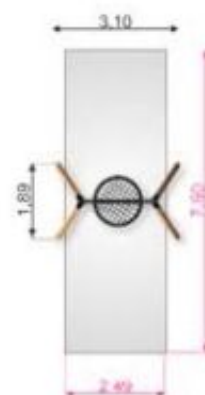

1:200



11131
DOUBLE SWING (BIRD NEST)

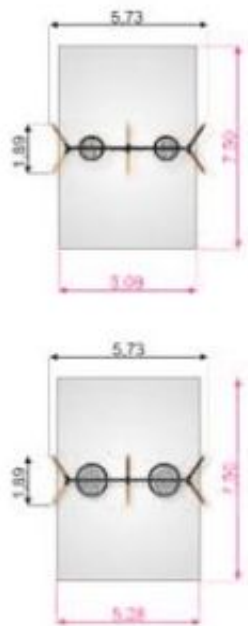

Ø 90

1:300

Ø 120



3+



2,35 m



1,35 m



W2W
METAL

3 h



11185
TRIPLE SWING

Ø 90

Ø 120



3+



2,35 m



1,40 m

W2W
METAL



3 h

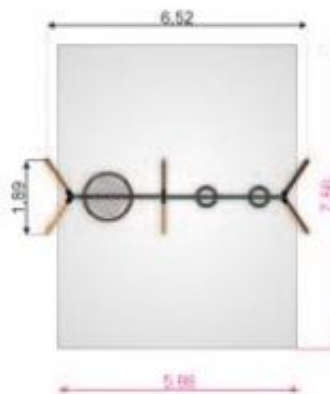
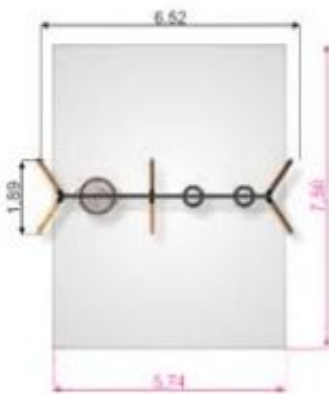

1:200



11182

1+2 SWING

-  1+
-  2,35 m
-  1,40 m
- W2W
METAL
-  3 h

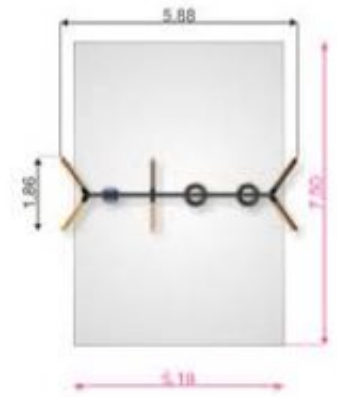





1:200



11180

2+2 SWING

-  1+
-  2,35 m
-  1,30 m
- W2W
METAL
-  3 h

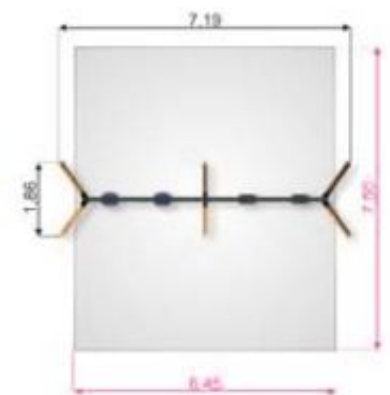

1:200

11140
WOODEN TYRE SWING



1:200



3+



2,48 m



1,35 m



W2W



2,5 h



11189
SIX ARM SWING

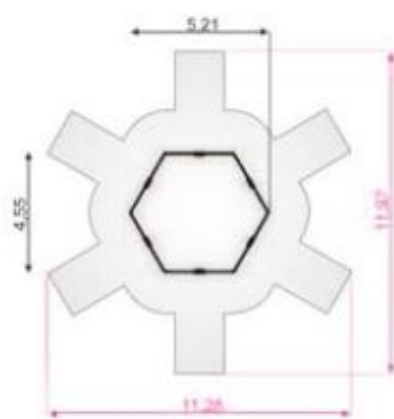

1:200



3+



2,40 m



1,26 m



W2W

METAL

5 h



13060

BNS SWING ROBINIA 2 POSTS



3+ 1,59 m 1,00 m 2,5 h



1:200

13025

FLEXI SIT SWING



3+ 1,60 m 0,91 m 2,5 h



1:200



13027

HAMMOCK



3+ 1,50 m 1,26 m 2,5 h



1:200

13024

DOUBLE SWING



3+ 2,40 m 1,40 m 2,5 h



1:200

13022

NATURE SWING



1+ 2,40 m 1,30 m 2,5 h



1:200

13023
SWING

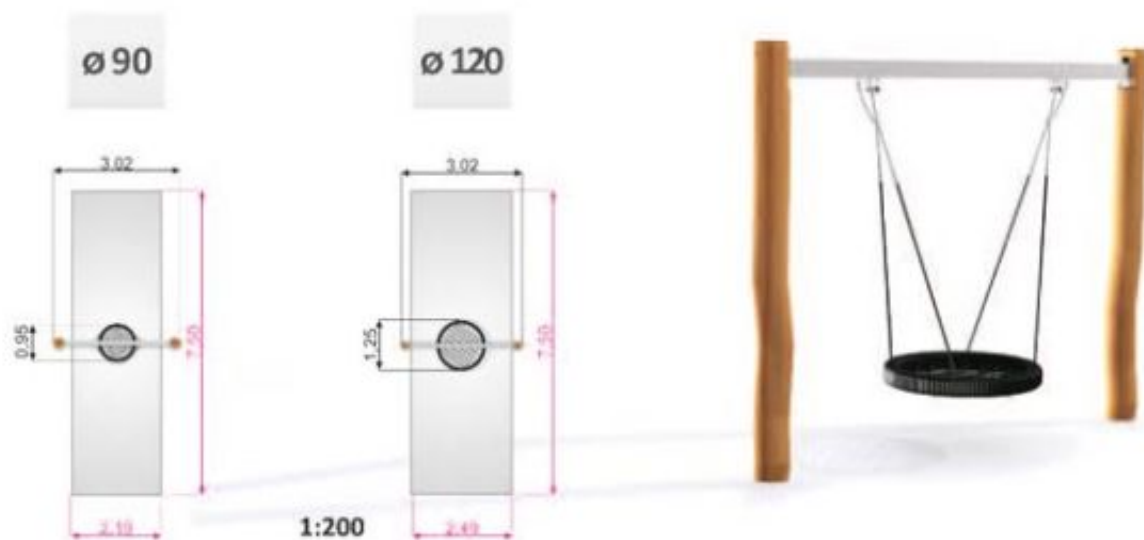

- 3+
- 2,40 m
- 1,35 m
- 2,5 h



13062
BNS SWING ROBINIA 4 POSTS

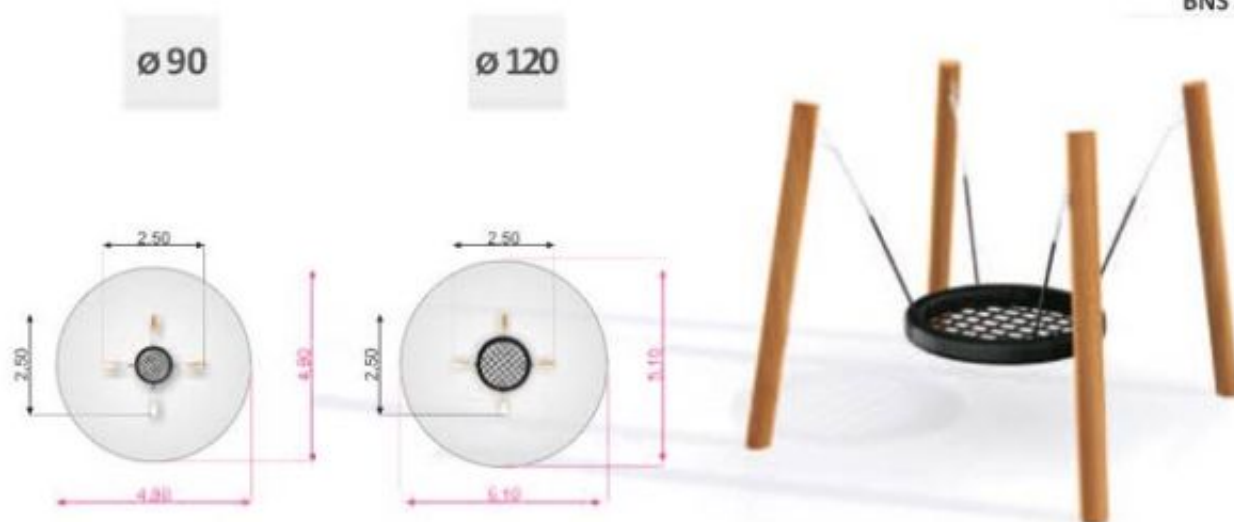

- 2+
- 1,59 m
- 0,55 m
- 3,5 h

1:200

12161

SINGLE SILVER SWING



1:200



12162

DOUBLE SILVER SWING



1:200



12168

TORNADO SWING



1:300

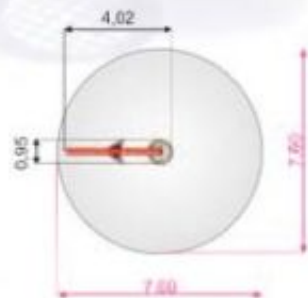

MODIFICATION

12103

SILVER SWING BNS



ø 90

ø 120



1:200

17402
SINGLE SWING SOLARIS



17401
SINGLE SWING SOLARIS



17403
DOUBLE SWING SOLARIS



17404
DOUBLE SWING SOLARIS



12300
BABY SWING



12160
YOUTH SWING

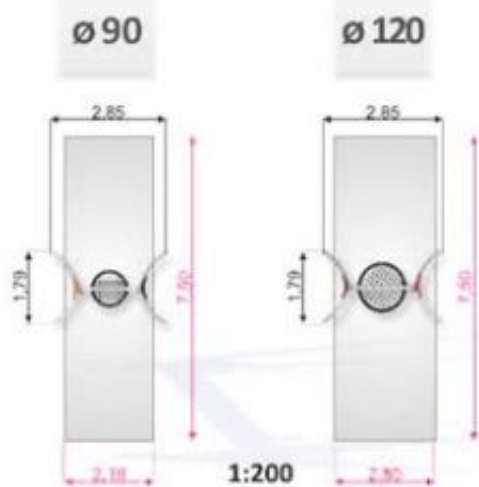

17405
SWING SOLARIS BNS



50028

WHEELCHAIR SWING



1+



2,61 m



1,30 m



3 h

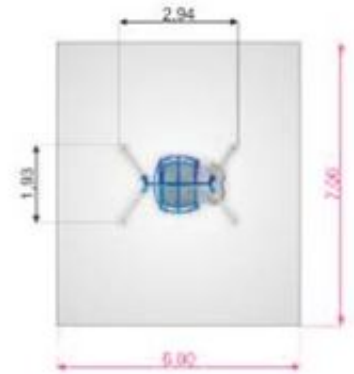

1:200

12080

HAMMOCK



3+



1,45 m



1,20 m



2 h

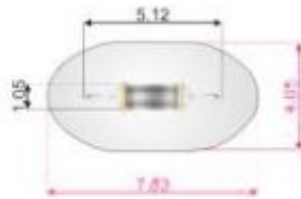

1:300



17406

BNS SWING 3 POSTS



3+



2,56 m



1,50 m



2,5 h



1:300



17101

SWING



3+



3,00 m



1,30 m



2,5 h



1:200



17100

HAMMOCK



3+



2,70 m



0,55 m



2 h

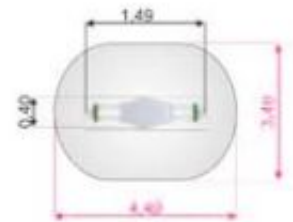

1:200



20051

BUFFER (SEPARATOR FOR SWINGS)



1,5 h



20052

BUFFER (SINGLE UNIT)



1 h



TS • TSPF*
TIRE SEAT

*PAH-free



SS
SAFETY SEAT



BNS90 • BNS120
BIRD NEST SEAT



TBS
TIRE BABY SEAT



FS
FLEXI SEAT



BS
BABY SEAT



SAS
SWING SEAT SAS



GBNS
SWING SEAT GBNS



SAND & WATER PLAY



13038
TRIANGLE



1:200



13039
5 - ANGLE PALISADE BOX

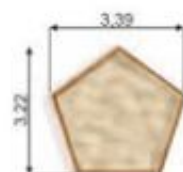

1:200



13032
PALISADE HORIZONTAL

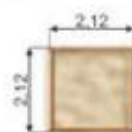

1:200





10700 SANDBOX

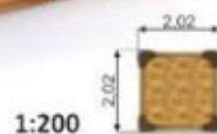

Also available in modular sizes:
3x3 m, 4x4 m, 3x4 m etc.

10860 SANDBPIT

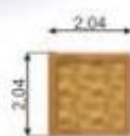

1:200



20050 DINO SANDBOX BASE



20050 + 10860



20050 + 10700



20050 + 19700





13031 SAND EDGING PEGS 40 cm (RM)

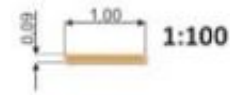

13037 SAND EDGING BOARDS 60 cm (RM)

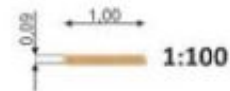

13050 SANDBOX

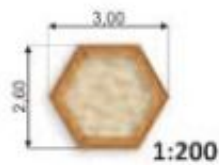

13033 PALISADE HORIZONTAL



13035 LARCH BEAM (RM)



13036 LARCH BOARD SECTION (RM)



13030 LARCH BOARD SECTION LOW



13034 OAK BEAM SECTION (RM)





10733 SAND & WATER PLAY TABLE

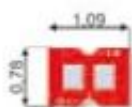

10734 SAND & WATER PLAY TABLE II

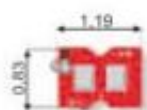

1:100



10735 SAND & WATER PLAY

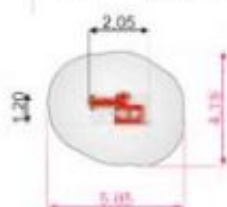

1:300



10731 SAND & WATER PLAY

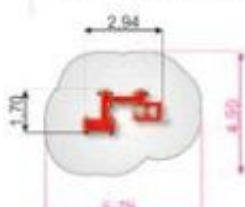

1:300

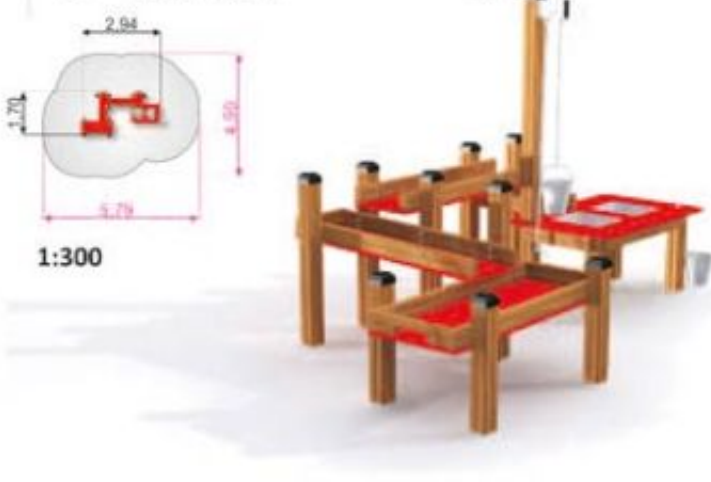

10895
EXCAVATOR



A: 0,23 m 1,15 m 1 h
B: 1,40 m

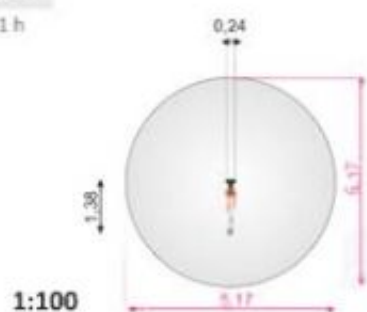

1:100



12353
SQUARE BENCH AND TABLE



1+ 0,45 m 0,45 m 2 h

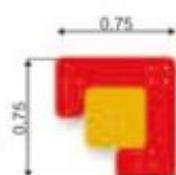

1:50



12351
TABLE AND CHAIR



1+ 0,45 m 0,45 m 1,5 h

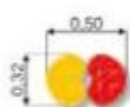

1:50



12357
TRIANGLE SEAT AND TABLE



1+ 0,47 m 0,47 m 2 h

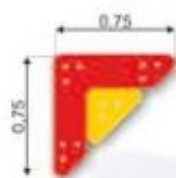

1:50



12362
HEART TABLE



1+ 0,45 m 0,45 m 1 h



1:50



12365
OCTOPUS TABLE WITH BASINS



1+ 0,73 m 0,45 m 2 h

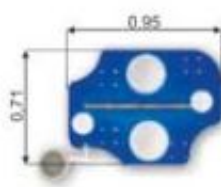

1:50



12359

DAISY



1+ 0,45 m 0,45 m 1 h

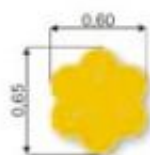

1:50



12366

BUTTERFLY TABLE



1+ 0,45 m 0,45 m 1 h

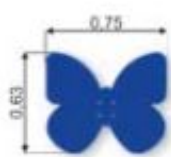

1:50



12354

SAND - WATER TABLE



1+ 0,47 m 0,47 m 2 h

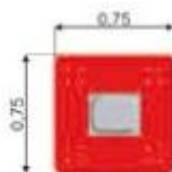

1:50



12361

BUTTERFLY TABLE WITH BASINS



1+ 0,45 m 0,45 m 2,5 h

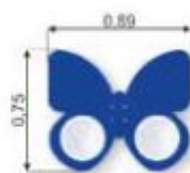

1:50



12363

CLOVER TABLE



1+ 0,45 m 0,45 m 1 h

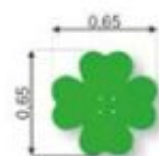

1:50



12364

CLOVER TABLE WITH BASINS



1+ 0,46 m 0,46 m 1,5 h

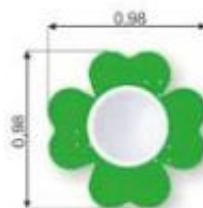

1:50



CLASSIC NATURE



19423

SMALL SHIP NATURE



1+ 2,16 m 0,55 m 8 h

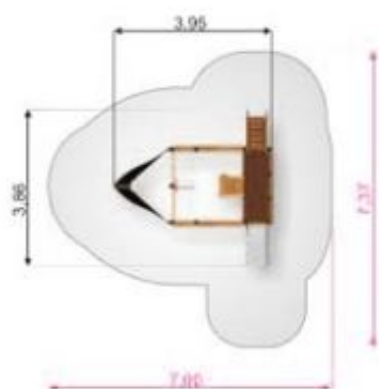

1:200



19425

SHIP NATURE



3+ 3,03 m 1,08 m 9 h

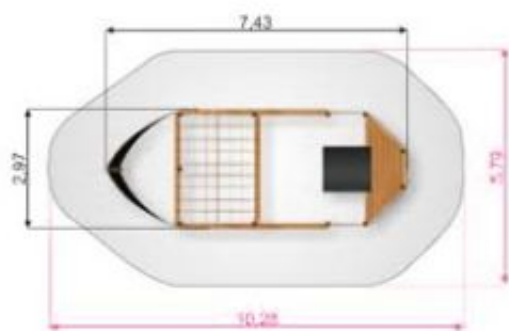

1:200



19746

BUS NATURE

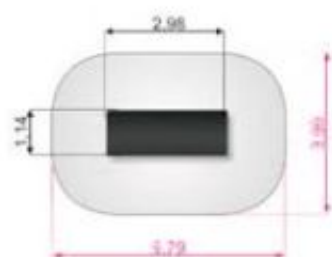

1:200



19738

LOCOMOTIVE NATURE

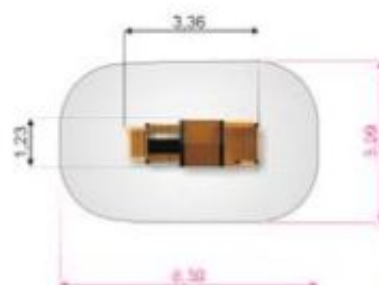

1:200



19737

LOCOMOTIVE WITH CARS NATURE

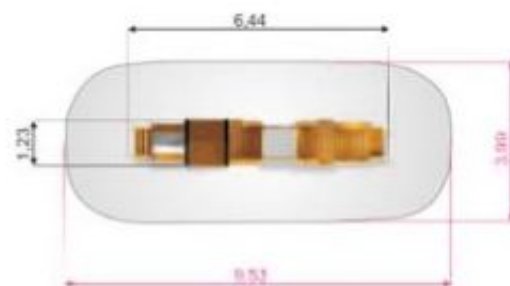

1:200

19708

PLAYHOUSE NATURE

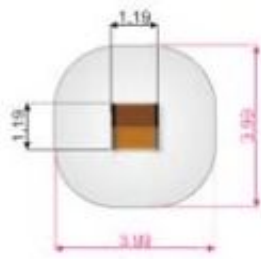

1:200

19724

WILLA NATURE

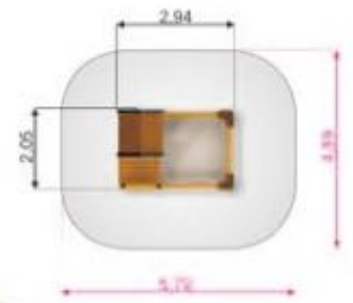

1:200



19720

PLAYHOUSE NATURE

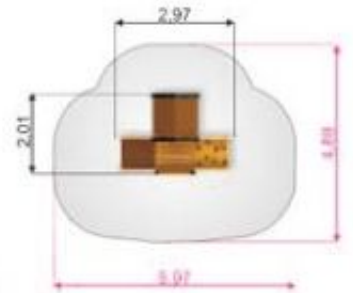

1:200

19712

VERANDA HOUSE NATURE

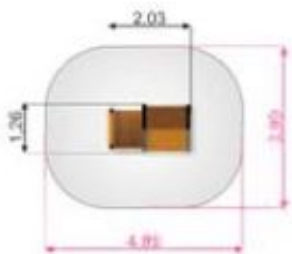

1:200



19751

COUNTRY HOUSE NATURE



3+



2,50 m



0,90 m

W2W
METAL



5,5 h

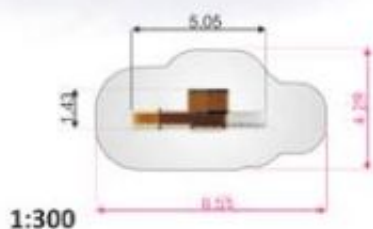

19761

KNIGHT'S CASTLE NATURE

3+



2,84 m



0,90 m



W2W
METAL



8,5 h

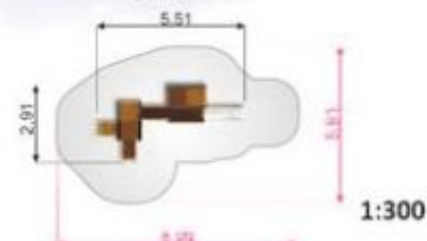

19762

TOWER NATURE



3+



2,55 m



1,45 m

W2W
METAL



9,5 h

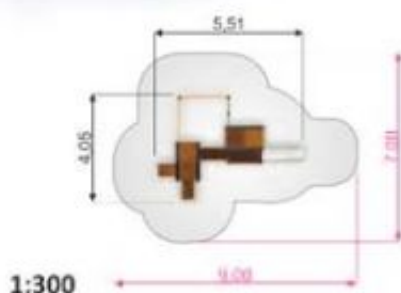

19765

FORTRESS NATURE

3+



2,07 m



0,55 m



W2W
METAL

9 h

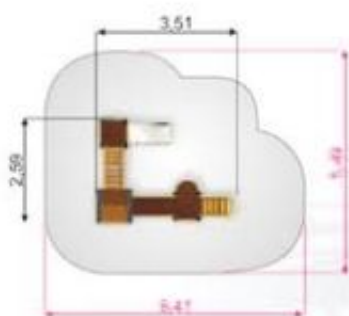

1:200

19780 THESEUS



1+ 1,33 m 0,55 m 6 h

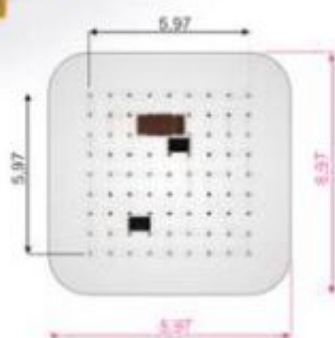
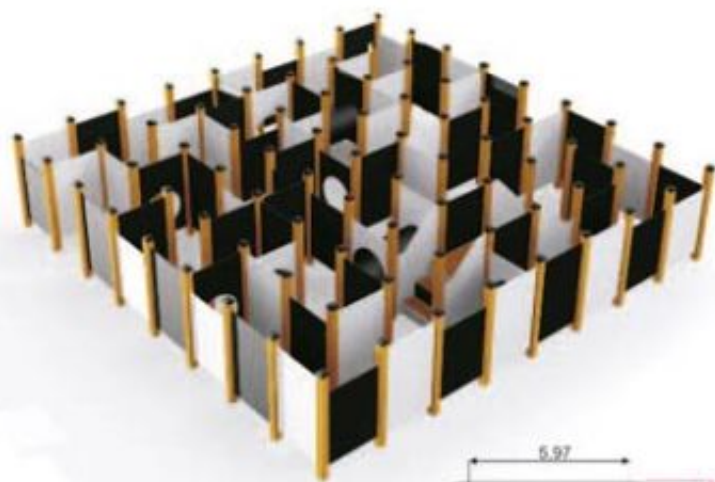

1:300

19781 ARIADNE



1+ 1,33 m 0,55 m 5 h

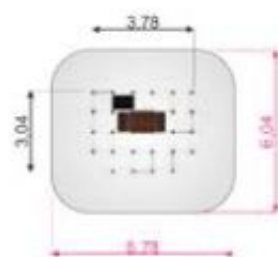

1:200



19148 CLIMBING KIOSK NATURE



3+ 2,16 m 2,05 m 8 h

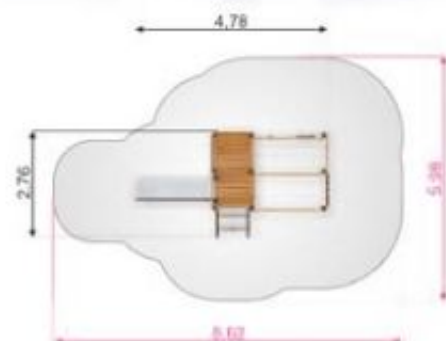

1:200

19147

LITTLE JUNGLE NATURE



1:200



19100

LOGO TOWER NATURE

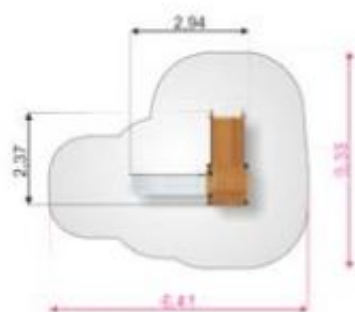

1:200

19168

SIX ANGLE AZTEC

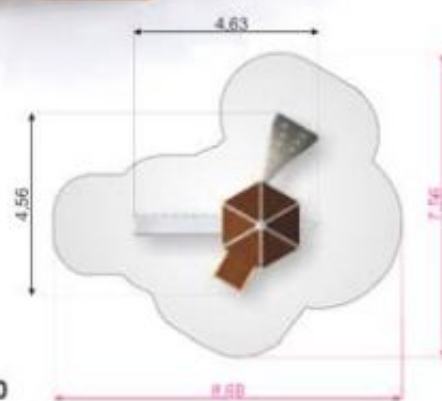

1:200

19600

CLIMBING BOOTH NATURE



3+



2,75 m



2,65 m



10 h

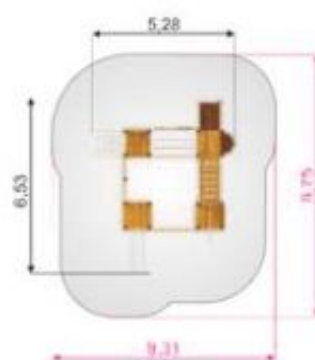

1:300



19333

ROMPING CORNER NATURE



3+



2,46 m



2,35 m



10 h

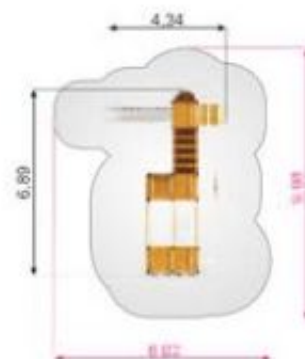

1:300

19242
SPIDERMAN

3+



2,76 m



2,35 m



W2W
METAL

8,5 h

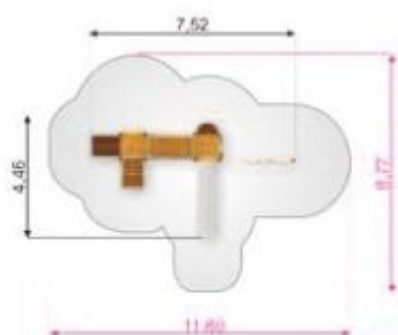

1:300



19240
ROMPING CENTER NATURE

3+



2,16 m



2,05 m



W2W
METAL

8,5 h

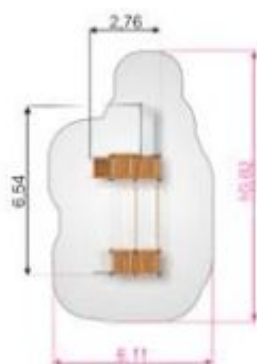

1:300



19265
GORILLA NATURE



3+



2,16 m



2,05 m



8,5 h

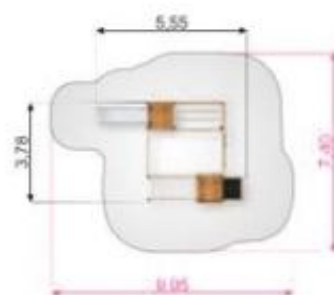

1:300

19405
CHALLENGER NATURE



3+



2,46 m



2,23 m



12 h

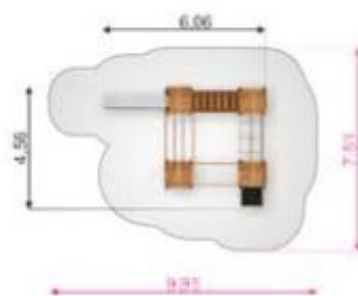

1:300

19415
CHALLENGER AZTEC



3+



2,46 m



2,22 m



11 h

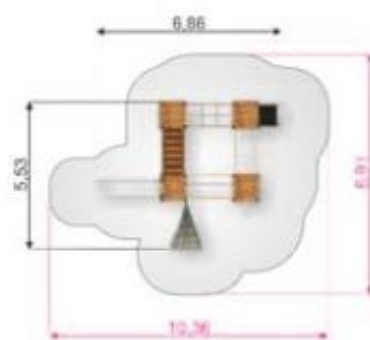

1:300

19416

CHALLENGER AZTEC NATURE II

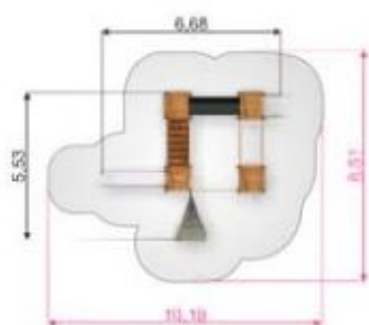

1:300



3+



2,46 m



2,00 m



W2W
METAL

12 h



19410

SQUARE PLAY NATURE

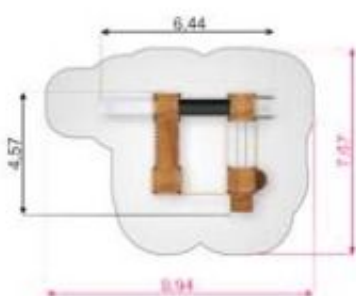

1:300



3+



2,16 m



2,05 m



W2W
METAL

12 h



19530

SEAROBBER CASTLE



3+



2,73 m



1,80 m



W2W
METAL



17 h

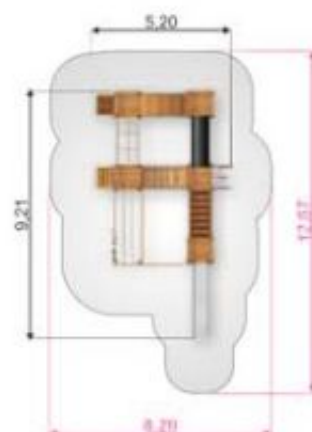

1:300

19320

MOTOR FUNCTION CENTER NATURE



3+



2,73 m



2,50 m



W2W
METAL



11 h

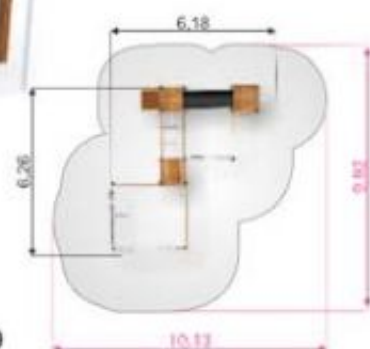

1:300



19540
KING-KONG NATURE

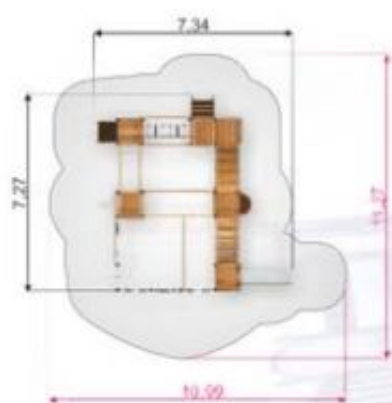

1:300



- 3+
- 3,33 m
- 2,10 m
- W2W
METAL
- 17 h



19541
KING- KONG NATURE II

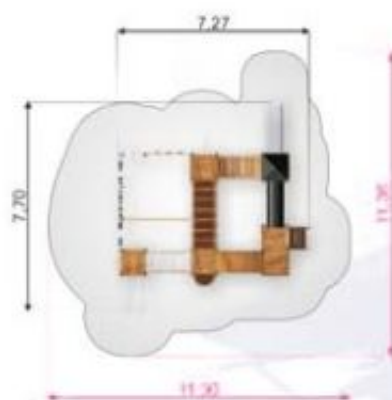

1:300



- 3+
- 3,33 m
- 3,00 m
- W2W
METAL
- 17 h



19594
MASTODONT



3+



3,23 m



2,70 m



W2W



23 h

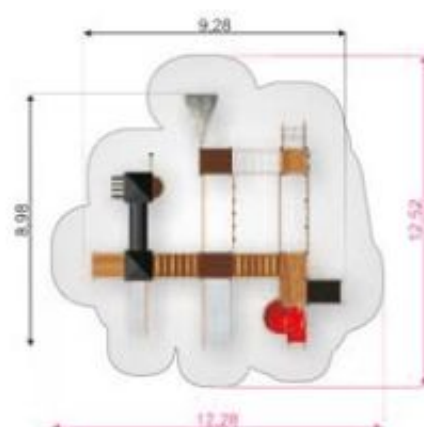

1:300



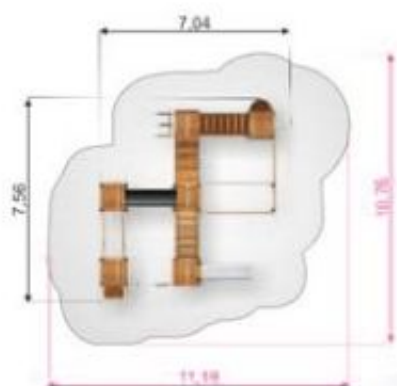

1:300



19550 TRITOWERS NATURE

3+



2,73 m



2,65 m



W2W
METAL

18 h

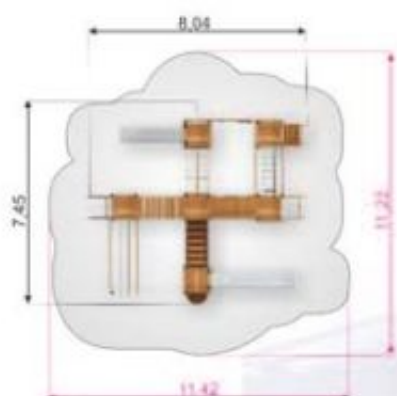

1:300



19592 SPACE STATION NATURE

3+



3,03 m



2,35 m



W2W
METAL

18 h

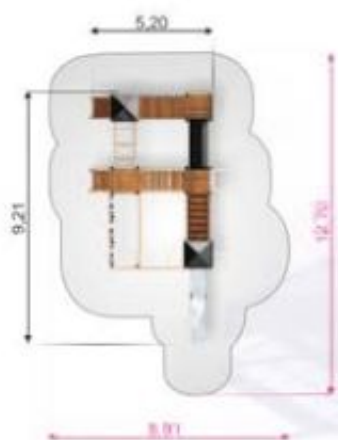

1:300



19532 EXPLORER

3+



3,80 m



2,65 m



W2W
METAL

19 h



PIONEER



10250 TWISTER



3+



4,13 m



2,45 m



W2W
METAL



10 h

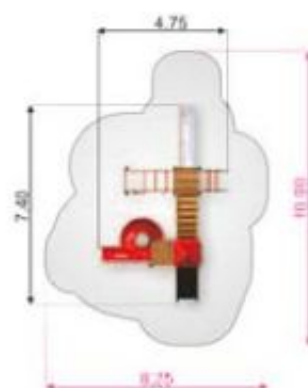

1:300

10330 LEMUR



3+



2,93 m



2,05 m



W2W
METAL



5 h

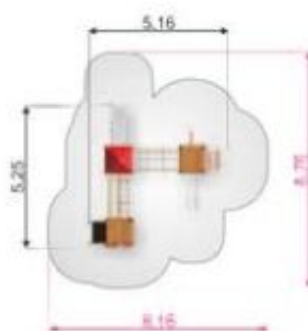

1:300

10240
ROMPING CENTER

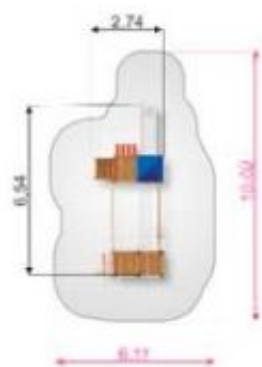

1:300



3+



3,20 m



2,05 m



W2W
METAL

8,5 h



10415
CHALLENGER- AZTEC

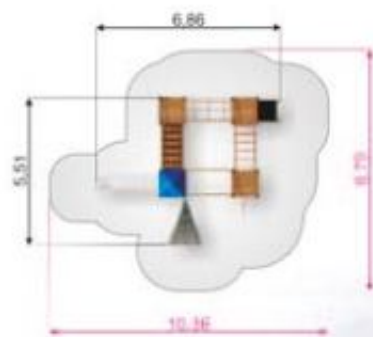

1:300



3+



3,53 m



2,36 m



W2W
METAL

11 h



10265 GORILLA

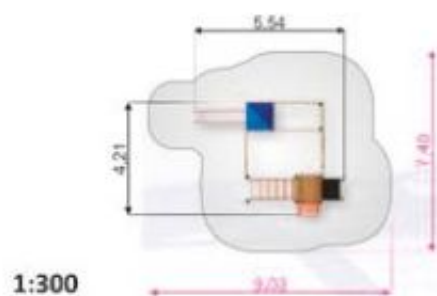

10405 CHALLENGER

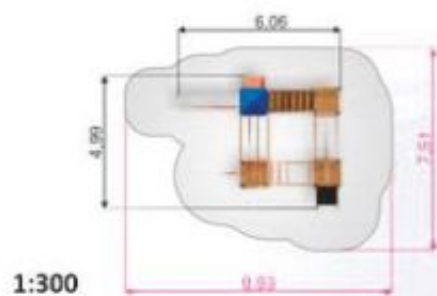

10406
JUBILEE UNIT

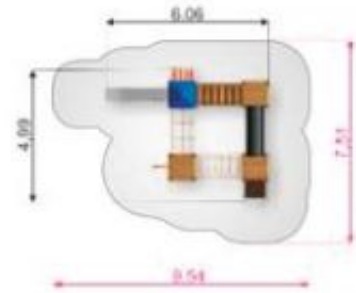

1:300



10410
SQUARE PLAY

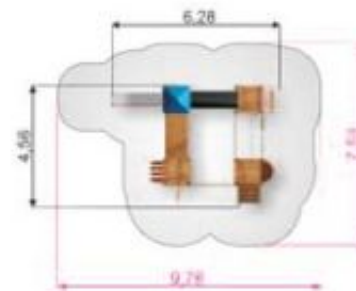

1:300

10167

MAST



W2W
METAL



3+

3,96 m

1,80 m

4 h

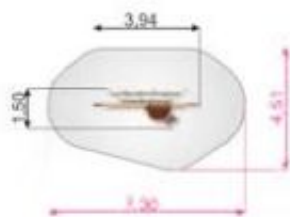

1:300



10168

SIX ANGLE WITH SUSPENSION BRIDGE



W2W
METAL



3+

3,20 m

2,05 m

10 h

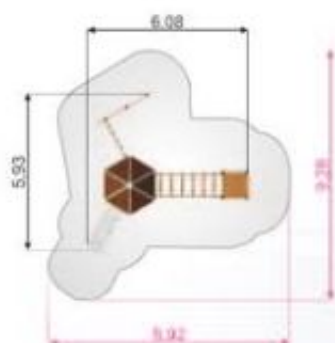

1:300



10166

THE SIX ANGLE



W2W
METAL



3+

3,19 m

2,35 m

9 h

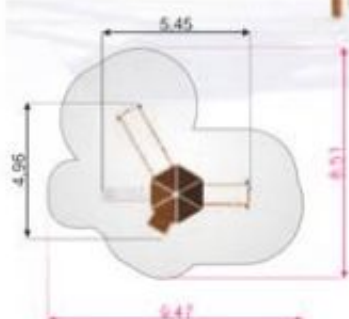

1:300



10171

SINGLE SWING WITH TOWER

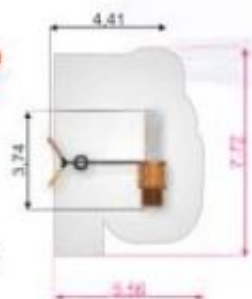

1:300

10173

SINGLE SWING WITH TOWER

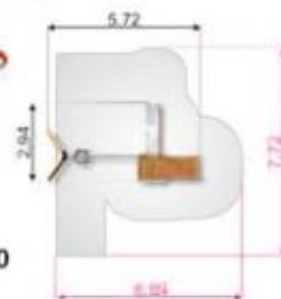

1:300



10172

DOUBLE SWING WITH TOWER

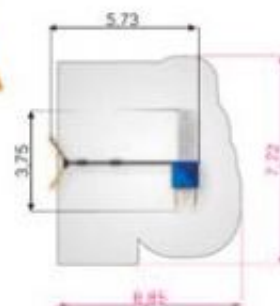

1:300



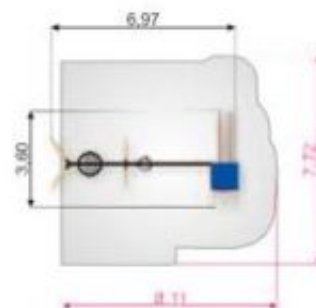

10174

BIRD NEST SWING WITH TOWER



1:300

10147
LITTLE JUNGLE

-  3+
-  2,13 m
-  2,05 m
- W2W
METAL
-  7,5 h

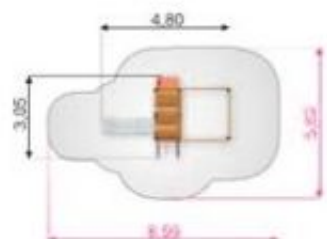

1:300

10144
KIOSK

-  3+
-  2,13 m
-  2,05 m
- W2W
METAL
-  6,5 h

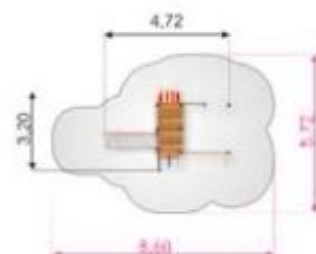

1:300

10148
CLIMBING KIOSK

-  3+
-  2,13 m
-  2,05 m
- W2W
METAL
-  8 h

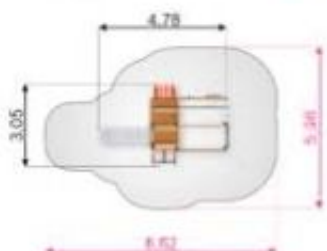

1:300



10108
GROCER'S

-  3+
-  2,13 m
-  2,05 m
- W2W
METAL
-  5,5 h

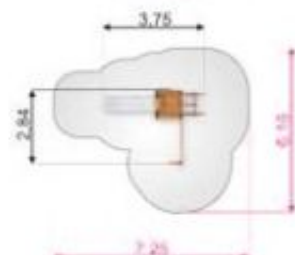

1:300

10332
ZEBRA

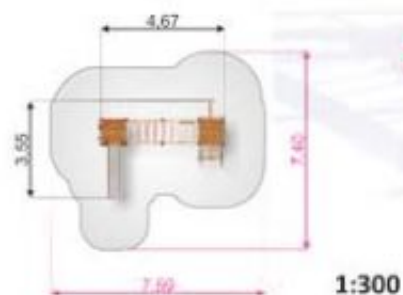

- 3+
- 2,16 m
- 2,05 m
- W2W
METAL
- 8,5 h



10101
LOGO TOWER WITH FIREPOLE

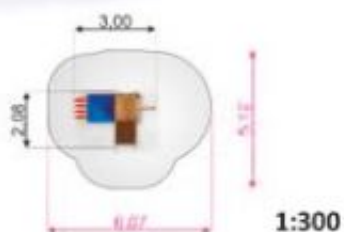

- 3+
- 3,51 m
- 2,35 m
- W2W
METAL
- 3 h



10105
LOGO TOWER WITH CLIMBING NET

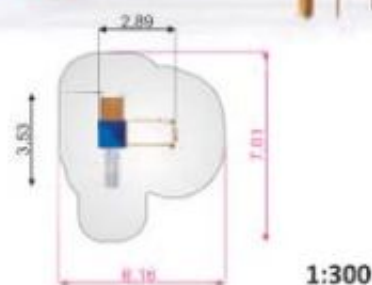

- 3+
- 2,93 m
- 1,75 m
- W2W
METAL
- 5 h



10100
LOGO TOWER

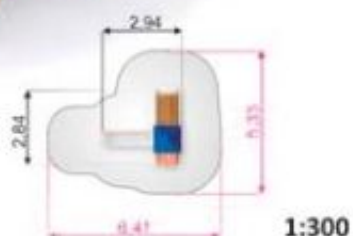

- 3+
- 3,20 m
- 1,20 m
- W2W
METAL
- 4 h



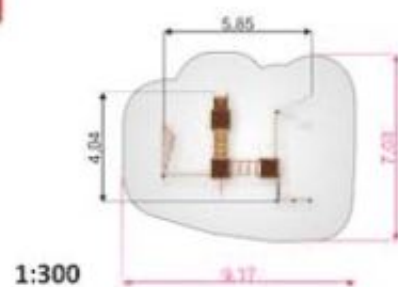

10331 PANTHER

-  3+
-  2,16 m
-  2,02 m
- WZW
METAL
-  8,5 h



10612 CLIMBING BOX

-  3+
-  2,15 m
-  2,05 m
- WZW
METAL
-  2 h

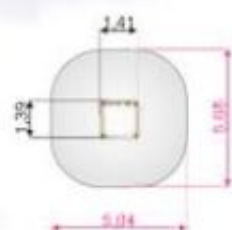

10610 CHIMPANZEE

-  3+
-  2,16 m
-  2,05 m
- WZW
METAL
-  7,5 h

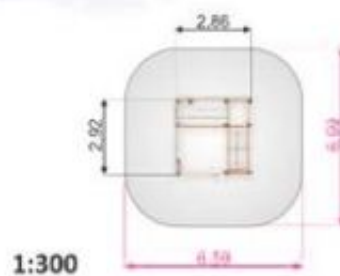

10620
ACTIVITY CENTER

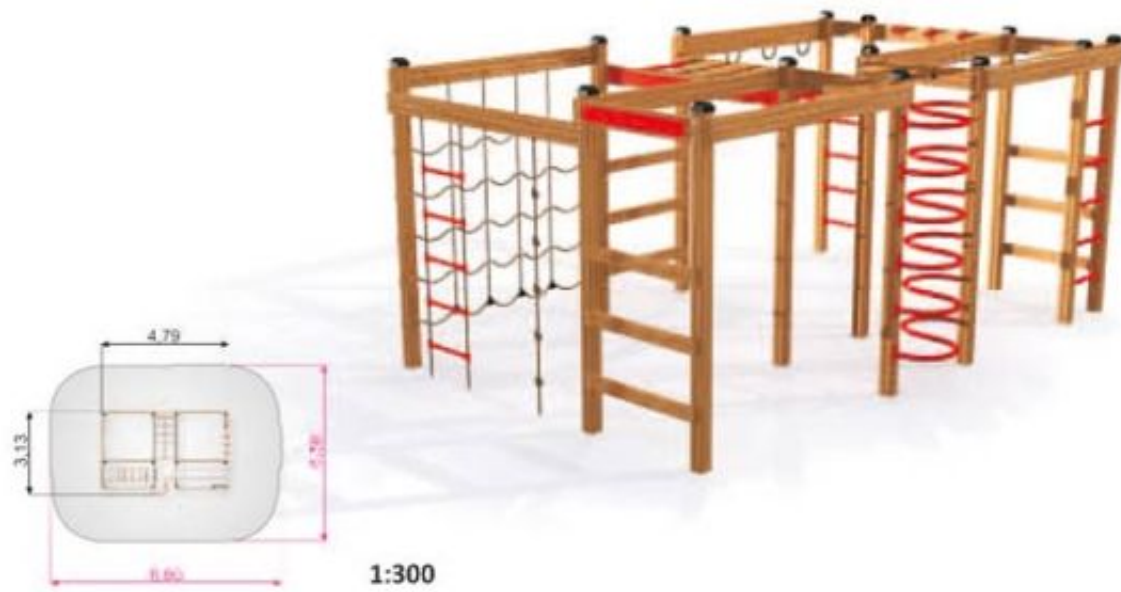

- 3+ 
- 2,16 m 
- 2,05 m 
- W2W
METAL
- 8,5 h 

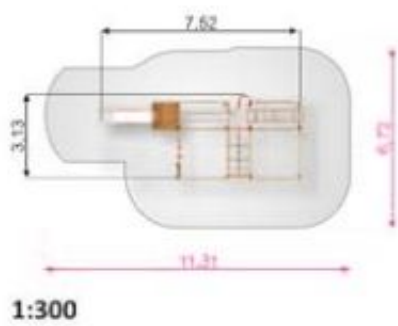

10621
ACTIVITY CENTER WITH SLIDE

- 3+ 
- 2,16 m 
- 2,05 m 
- W2W
METAL
- 10 h 



10642

POISON GROUND



3+



1,26 m



0,87 m

W2W
METAL



21 h

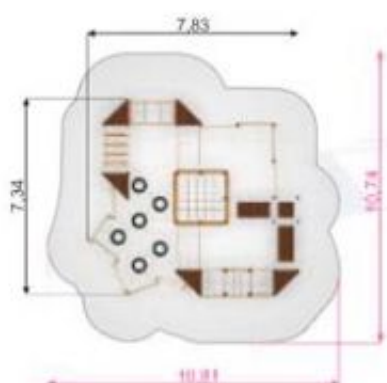

1:300



10643

COURSE



3+



1,23 m



0,87 m

W2W
METAL



12 h

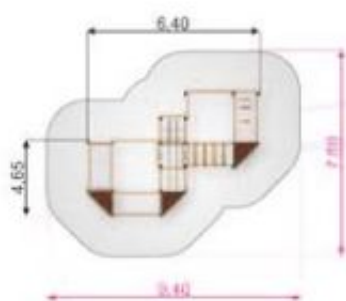

1:300



10663

TRAPEZOIDAL



10662

V-SHAPE NET

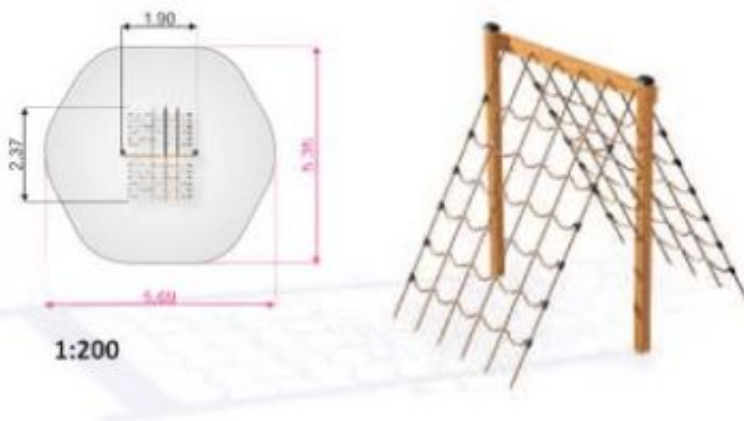

10668

HONEYCOMB



10665

HORIZONTAL LADDER



10664

HORIZONTAL LADDER II



10667 JUMPING PEGS

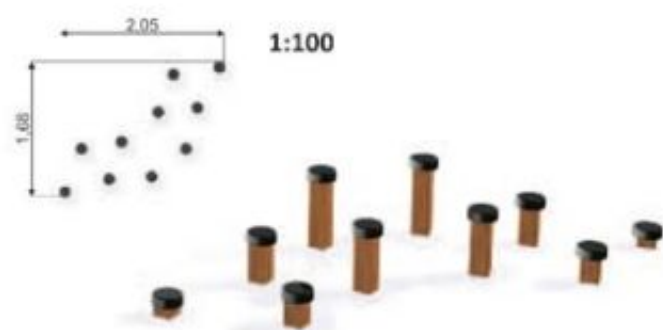

10671 VERTICAL LADDER

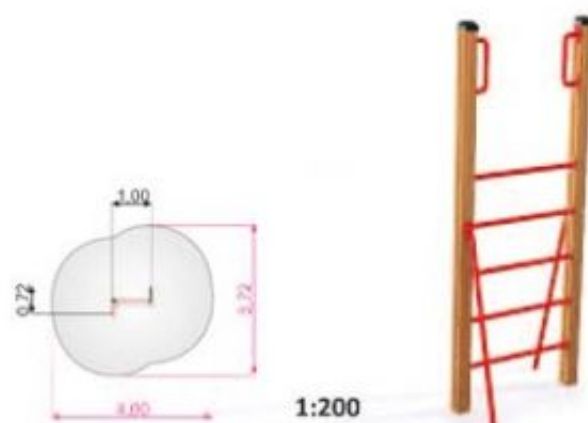

10660 BALANCE

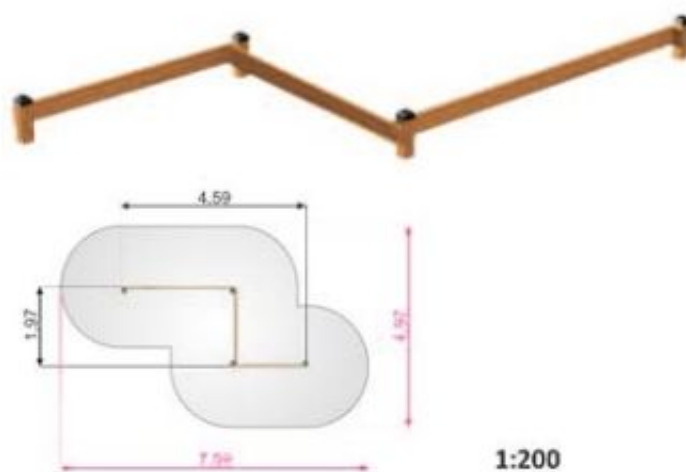

10646 TUNNEL

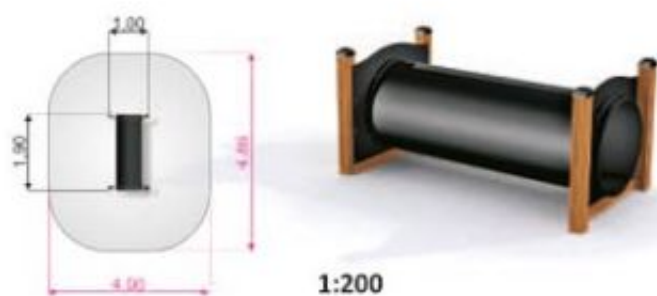

10666 CHAIN BRIDGE



10899

SOMERSAULT SINGLE

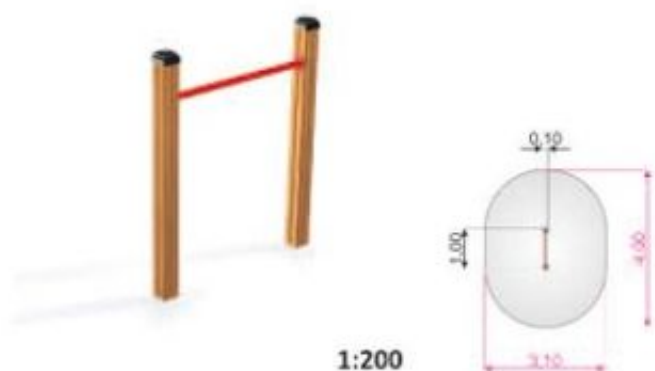

10900

SOMERSAULT DOUBLE

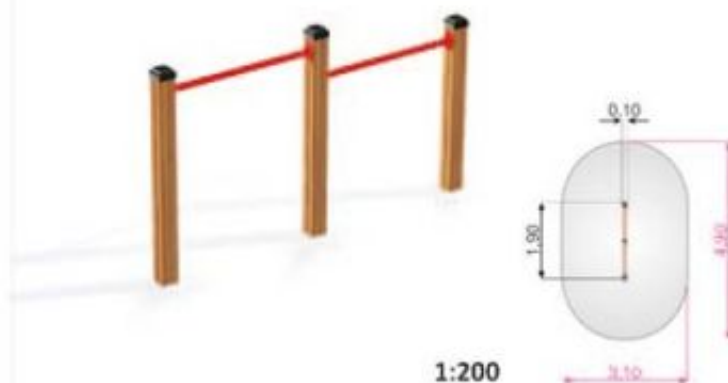

10901

SOMERSAULT TRIPLE

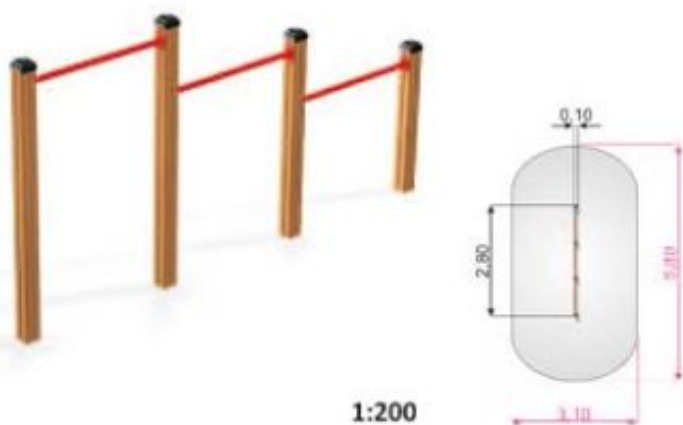
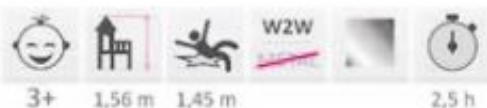

PIONEER TRIM TRAIL COMBINATION

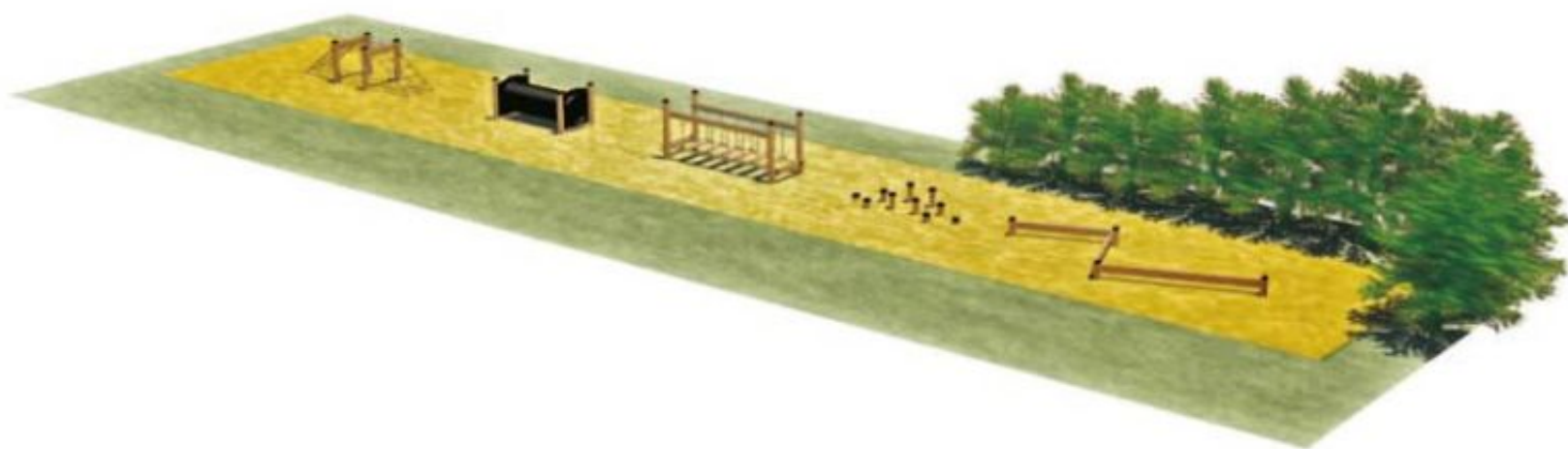

10530

SEAROBBER CASTLE

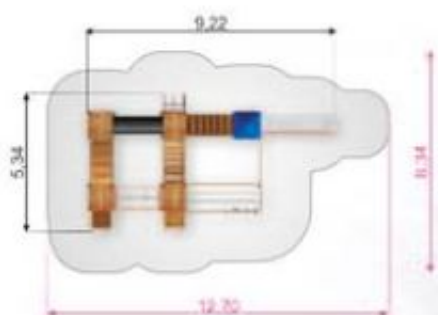

1:300



10320

MOTOR FUNCTION CENTER

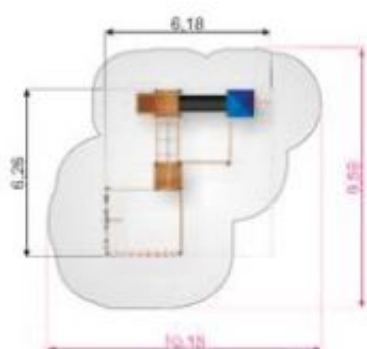

1:300



10420

SPHINX

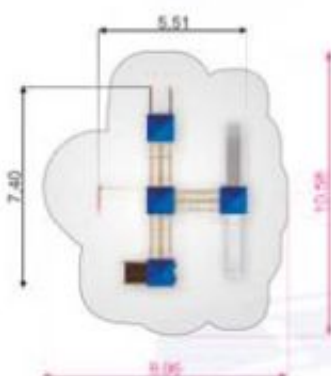

1:300





10590
SPACE STATION

			W2W METAL	
3+	3,50 m	2,35 m		20 h

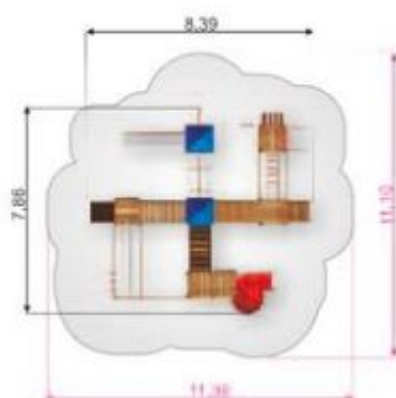

10540
KING-KONG

			W2W METAL	
3+	3,33 m	3,00 m		17 h

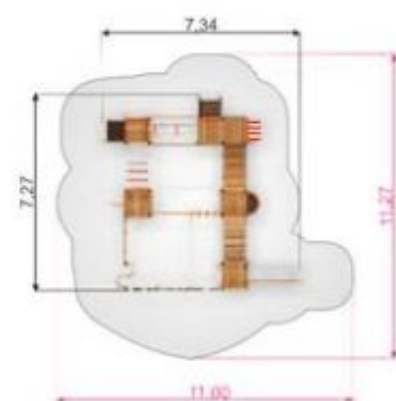

10550 TRITOWERS

-  3+
-  3,80 m
-  2,65 m
- W2W
METAL
-  21 h

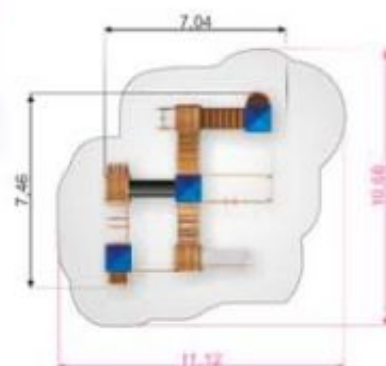

1:300

10595 GIGANTIC

-  3+
-  3,80 m
-  3,00 m
- W2W
METAL
-  86 h

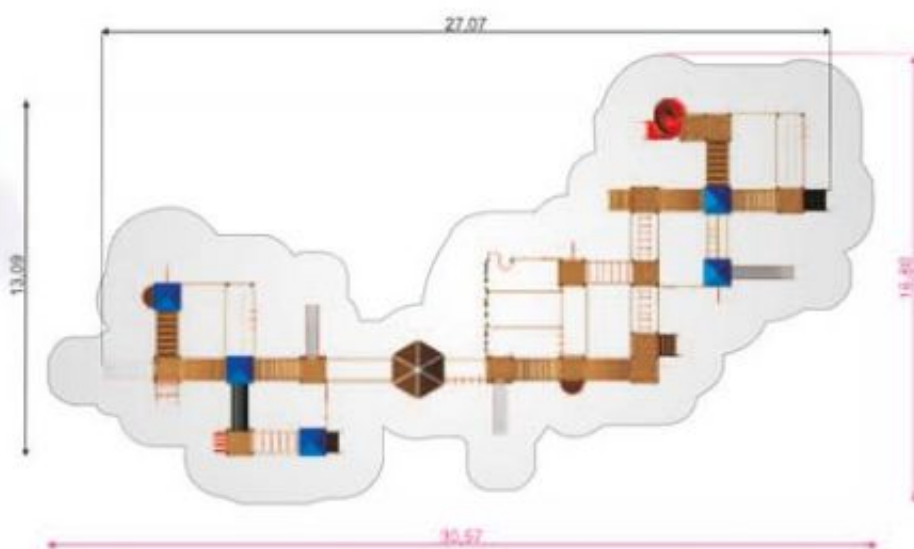

1:300



11426
BOUNTY

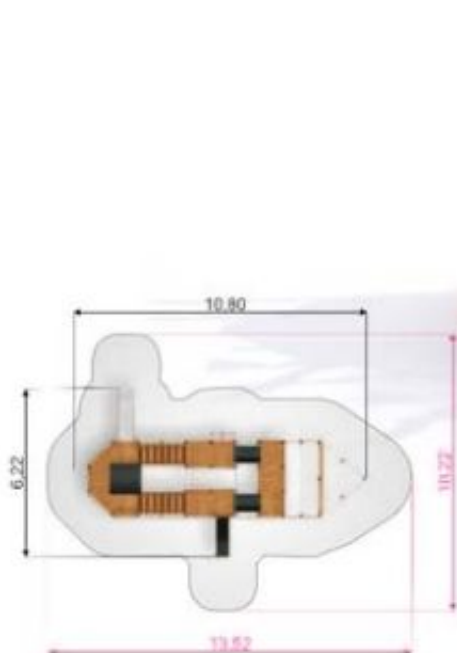



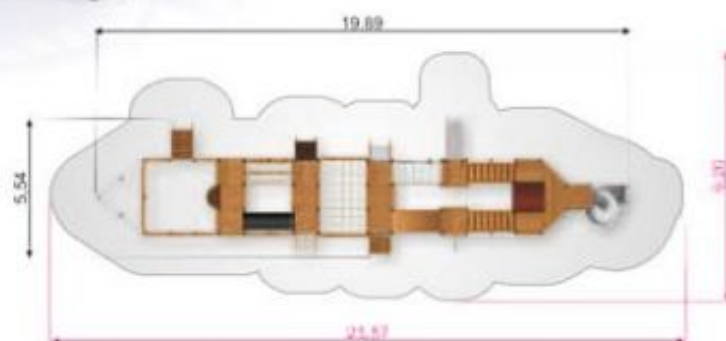

- 3+ 
- 4,26 m 
- 1,75 m 
- W2W 
- 32 h 

1:300

11428
MAJESTIC



1:300

- 3+ 
- 4,26 m 
- 2,10 m 
- W2W 
- 56 h 



10290
TINTAGEL

			W2W METAL	
3+	4,73 m	1,20 m		8,5 h



10435
CAMELOT

			W2W METAL	
3+	4,73 m	2,05 m		17 h

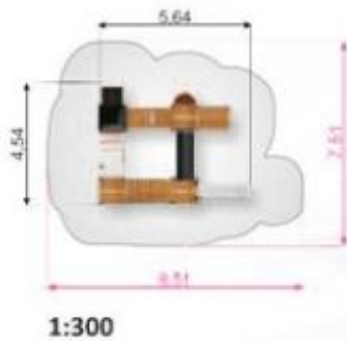

10535
WINDSOR

			W2W METAL	
3+	5,35 m	2,05 m		38 h

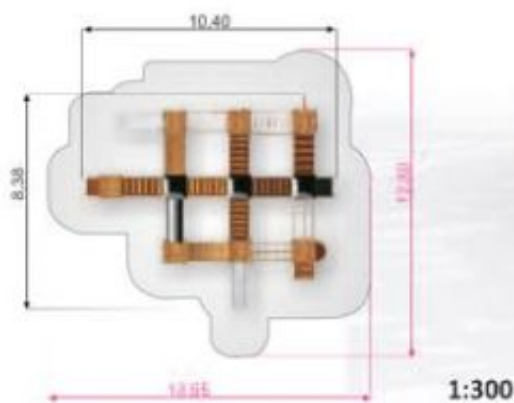

11536
APOLLO



1:300

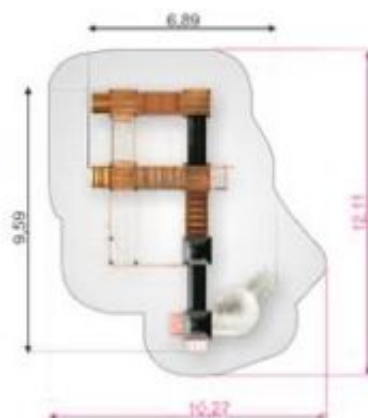

3+



3,50 m



2,36 m



W2W
METAL

21 h



10560
CITADEL



1:300

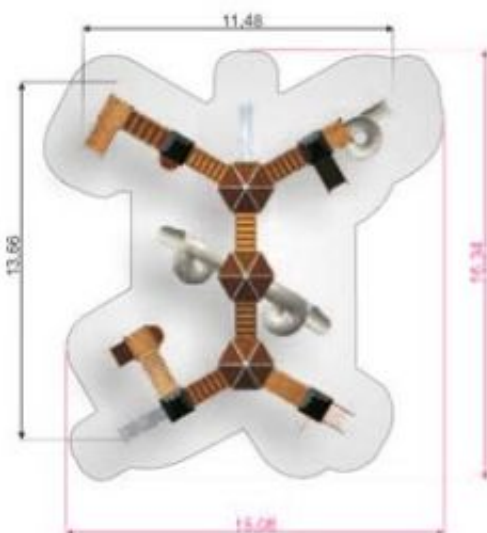

3+



5,06 m



2,10 m



W2W
METAL

60 h



20001-1
WINDSOR WITH DRAGON



3+



20001
DRAGON



A: 3,30 m
B: 6,00 m



20005
DRAGON TAIL



A: 1,20 m
B: 1,90 m



20003-1
SLIDE WITH DRAGON BACK



3+



20003
DRAGON BACK SET



A: 1,30 m
B: 1,77 m



20004-1
TRAPEZOIDAL WITH DRAGON CLAWS



3+



20004
DRAGON CLAWS



A: 0,70 m
B: 2,00 m



20002-1
BABY DRAGON



3+



20002
TOWER WITH BABY DRAGON



A: 1,75 m
B: 1,60 m



HILL SLIDE

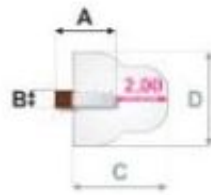

NUMBER	A x B	C x D	HILL HEIGHT	
10809	2,21 x 0,70	3,56 x 3,48	0,75	0,15
10810	2,64 x 0,70	3,97 x 3,48	1,05	0,15
10811	3,05 x 0,70	4,40 x 3,48	1,35	0,15
10812	3,50 x 0,70	4,83 x 3,48	1,65	0,15
10813	3,92 x 0,70	5,25 x 3,48	1,95	0,15

HILL SLIDE WIDE

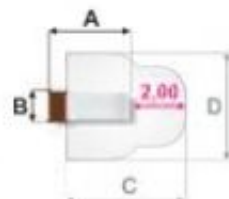

NUMBER	A x B	C x D	HILL HEIGHT	
10816	2,64 x 1,19	3,97 x 3,97	1,05	0,15
10817	3,05 x 1,19	4,40 x 3,97	1,35	0,15
10818	3,50 x 1,19	4,83 x 3,97	1,65	0,15
10819	3,92 x 1,19	5,25 x 3,97	1,95	0,15

HILL SLIDE

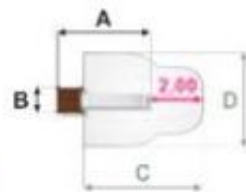

NUMBER	A x B	C x D	HILL HEIGHT	
10820	2,98 x 0,99	3,97 x 3,48	1,05	0,15
10821	3,40 x 0,99	4,40 x 3,48	1,35	0,15
10822	3,83 x 0,99	4,92 x 3,48	1,65	0,15
10823	4,26 x 0,99	5,35 x 3,48	1,95	0,15

HILL SLIDE

NUMBER	A x B	C x D	HILL HEIGHT	
13003	2,90 x 1,20	4,10 x 3,50	1,05	0,25
13004	3,36 x 1,20	4,59 x 3,50	1,35	0,25
13005	3,80 x 1,20	5,02 x 3,50	1,65	0,25
13006	4,20 x 1,20	5,45 x 3,50	1,95	0,25

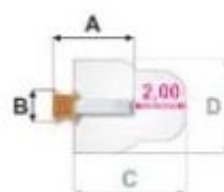

Hill Slide Wide

NUMBER	A x B	C x D	HILL HEIGHT	
13003D	2,90 x 1,75	4,10 x 4,00	1,05	0,25
13004D	3,36 x 1,75	4,59 x 4,00	1,35	0,25
13005D	3,80 x 1,75	5,02 x 4,00	1,65	0,25
13006D	4,20 x 1,75	5,45 x 4,00	1,95	0,25

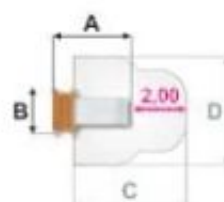

10669 PIONEER HILL STAIRS



MODERN NATURE



30856
SMART MODERN NATURE



3+



2,07 m



0,55 m



W2W
METAL



7,5 h

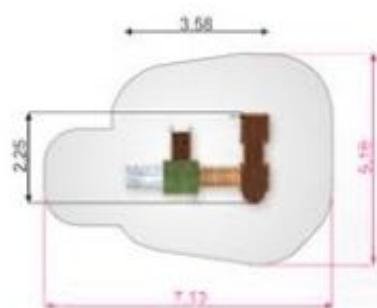

1:200



30857
RUBIK MODERN NATURE



3+



2,07 m



0,55 m



W2W
METAL



8 h

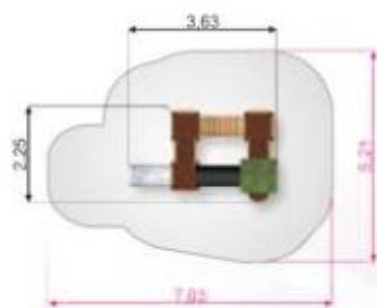

1:200



30148

CLIMBING KIOSK MODERN NATURE

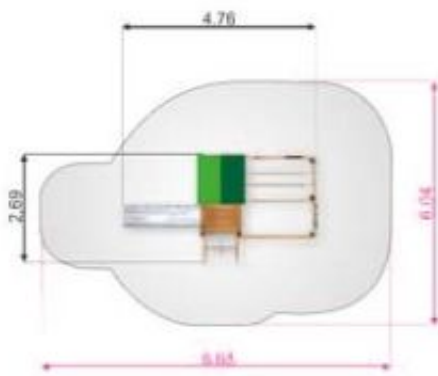

1:200



30144

KIOSK MODERN NATURE

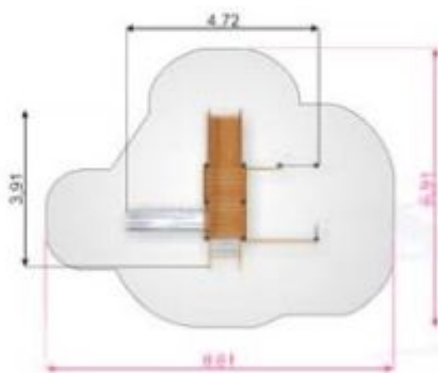

1:200



30852

NEMO MODERN NATURE

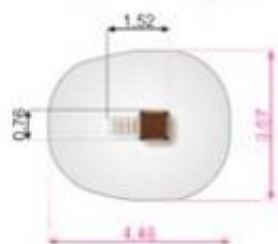

1:200

30100

LOGO MODERN NATURE

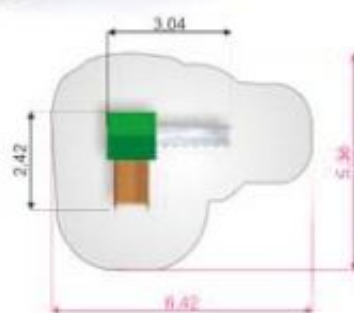

1:200

30200

HEXAGON MODERN NATURE

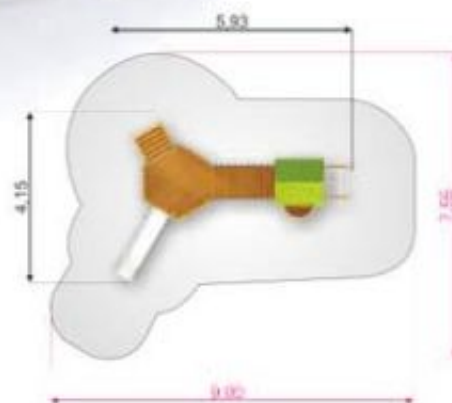
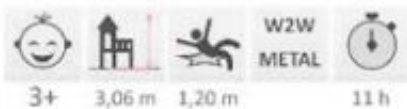

1:200

30201

TRIANGLE MODERN NATURE

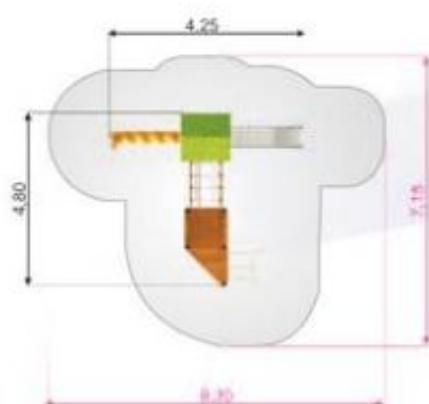

30202

ROMPING COTTAGE

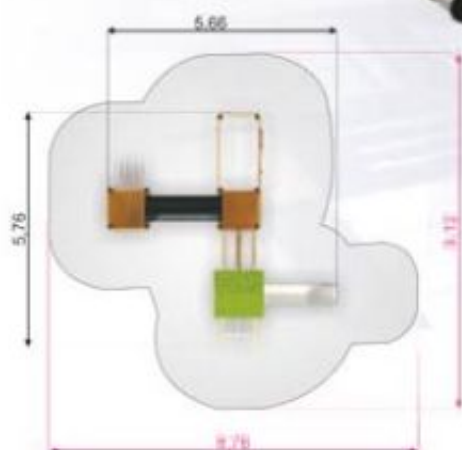

DREAMWORLD



13230 CRAYONS



1:200

13226 SPILLIKINS

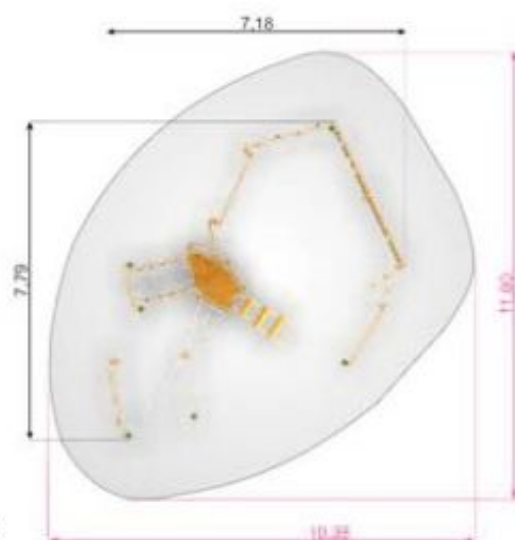

1:200

13043

CROOKED HOUSE



1+ 2,30 m 0,00 m 1,5 h

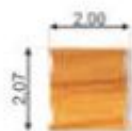

1:200



13150

ANNA'S PLAYHOUSE



1+ 2,42 m 0,35 m 10 h

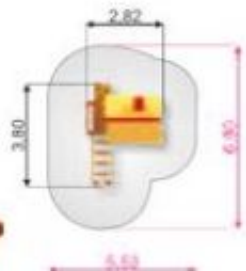

1:300

13152

OLLE'S PLAYHOUSE



1+ 2,62 m 0,55 m 9 h

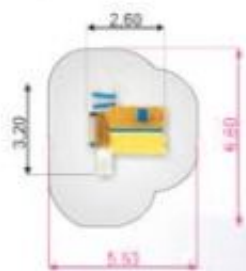

1:300



13154

BRITTA'S PLAYHOUSE



1+ 2,62 m 0,55 m 9 h

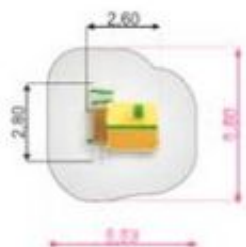

1:300

13153

LISA'S PLAYHOUSE



3+ 3,82 m 1,50 m 9,5 h



1:300



13151

NILL'S PLAYHOUSE



1+ 2,30 m 0,25 m 7 h

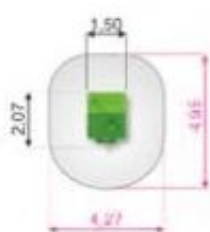

1:300



30225

NANNA'S PLAYHOUSE



3+ 3,20 m 0,90 m 10 h

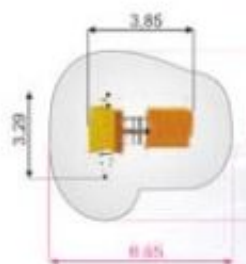

1:300



NATURE



13225 WOODEN HUT



1+



3,20 m



0,90 m



10 h

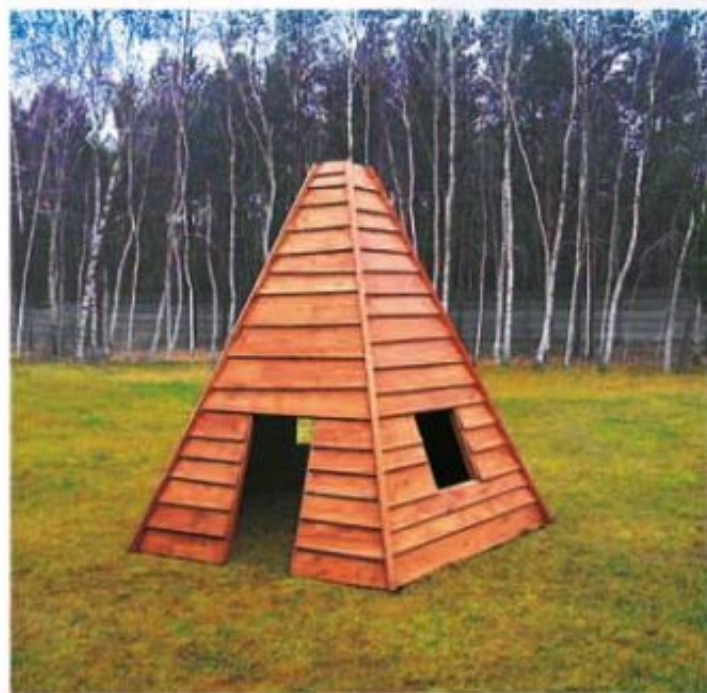
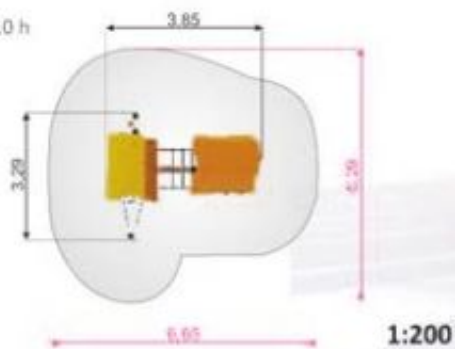

13045 WIGWAM



1+



3,20 m



0,00 m



6 h

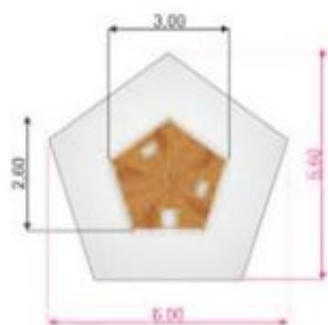



13040G
NATURE PLAYHOUSE GRASS ROOF



1+ 1,72 m 0,00 m 3 h

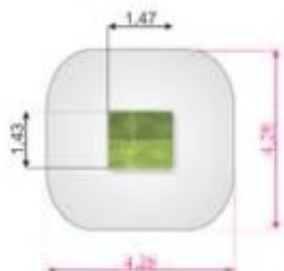

1:200

13040
NATURE PLAYHOUSE



1+ 1,76 m 0,00 m 2 h

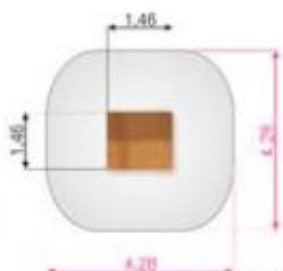

1:200



13044
SMALL HOUSE



1+ 1,90 m 0,00 m 1,5 h

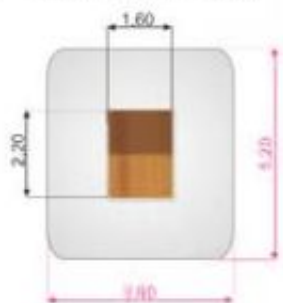

1:200

13044G
SMALL HOUSE GRASS ROOF



1+ 1,90 m 0,00 m 2,5 h

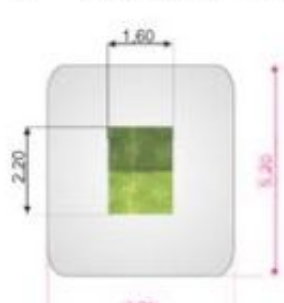

1:200

13047
VERANDA HOUSE NATURE



1+ 1,59 m 0,13 m 7 h

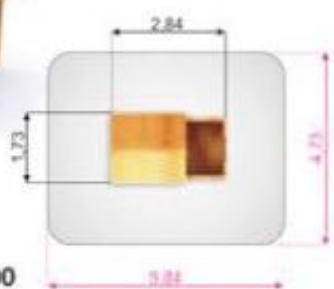

1:200

13047G
VERANDA HOUSE NATURE GRASS ROOF



1+ 1,59 m 0,13 m 7 h

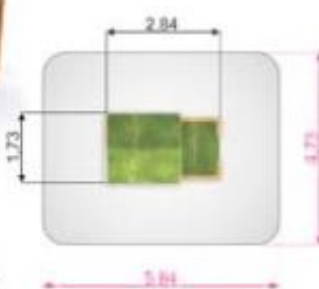

1:200

13080

FIREPIT SEATING

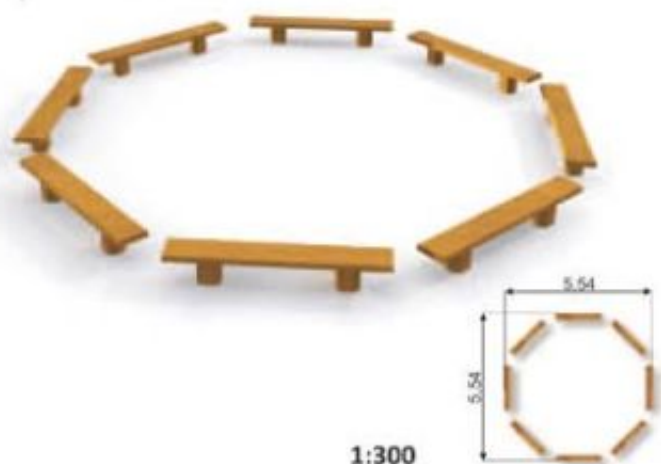

14190

TABLE & BENCH, NATURE



13046

SLEEP SHELTER



13072

FIREHOUSE

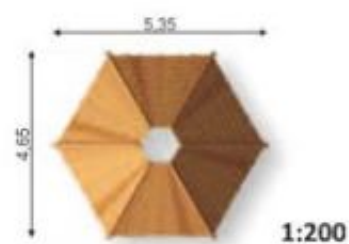

*Installation time for 3 persons

13074
FIREHOUSE



1:200

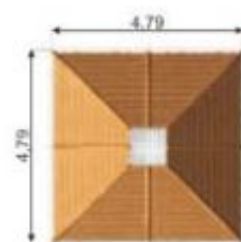

- 1+
- 3,20 m
- 0,00 m
- 18 h*

*Installation time for 3 persons



13078
LONG FIREHOUSE



1:200



- 1+
- 3,20 m
- 0,00 m
- 22 h*

*Installation time for 3 persons

13090
KILIMANJARO

-  3+
-  2,10 m
-  1,45 m
-  3,5 h

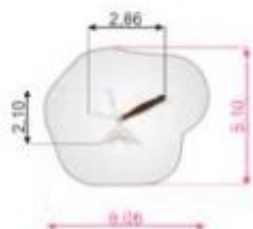

1:300

13091
VESUVIUS

-  3+
-  2,10 m
-  1,45 m
-  3,5 h

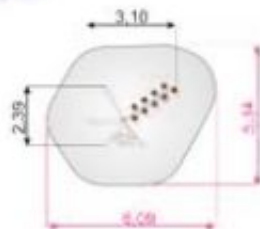

1:300



13681
TIPI II

-  3+
-  3,10 m
-  3,00 m
-  9,5 h

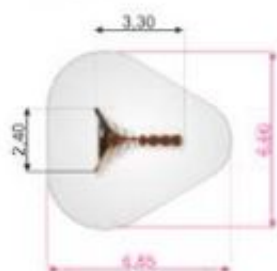

1:300

13680
TIPI I

-  3+
-  3,10 m
-  2,40 m
-  9,5 h

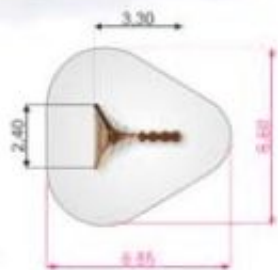

1:300



13105
SERENGETI



- 3+ 
- 2,40 m 
- 2,10 m 
- 8,5 h 

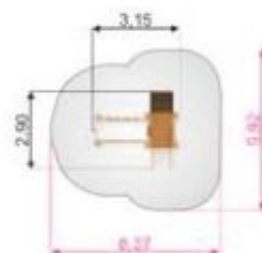

1:300

13100
SHERWOOD

- 3+ 
- 2,40 m 
- 2,34 m 
- 10 h 

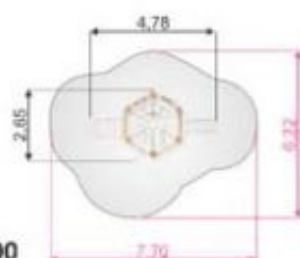

1:300



13102
YELLOWSTONE

- 3+ 
- 2,30 m 
- 2,30 m 
- 8 h 

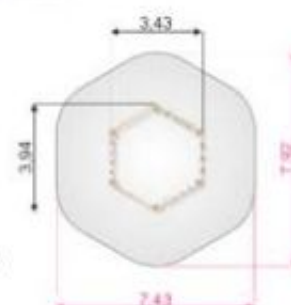

1:300

13113

ALV



3+



2,40 m



1,50 m



11 h

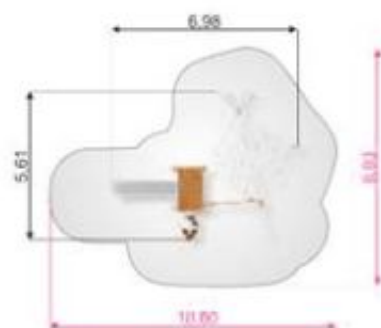

1:300



13106

STRANDA



3+



2,40 m



2,20 m



10 h

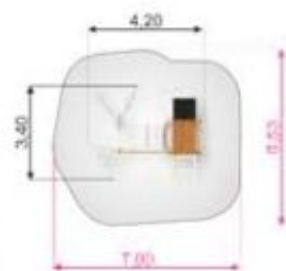

13111

KAMPINOS



3+



2,40 m



2,06 m



10 h

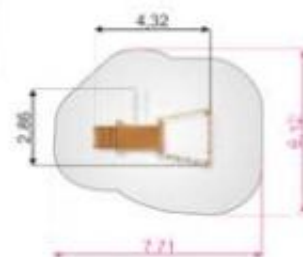

13140
NATURE SHIP

3+



3,62 m



2,06 m



17 h

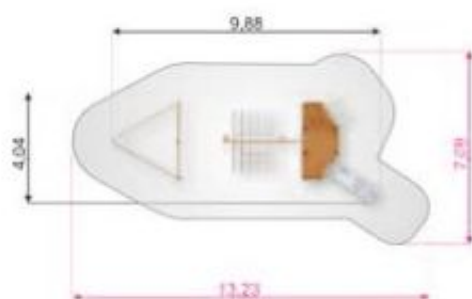

1:300



13104
YOSEMITE



3+



2,40 m



1,50 m



7,5 h

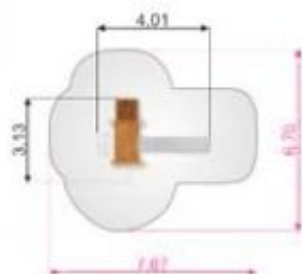

1:300



13222
BERGILA



3+



2,40 m



2,25 m



12 h

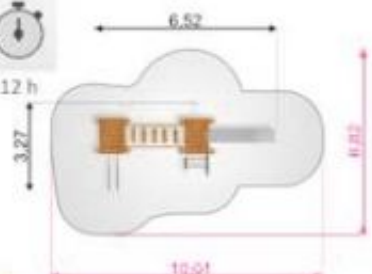

1:300



13221
ALSTAD



3+



2,40 m



2,30 m



11 h

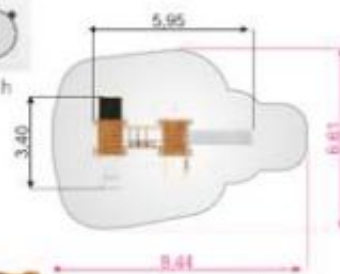

1:300



13510 KENTUCKY

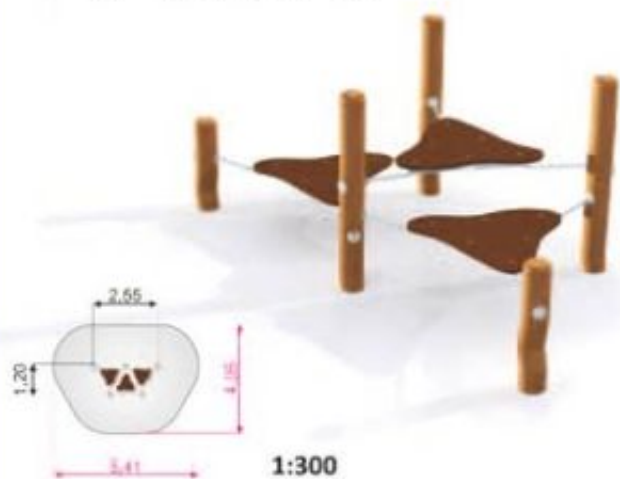

13512 KENTUCKY DOUBLE

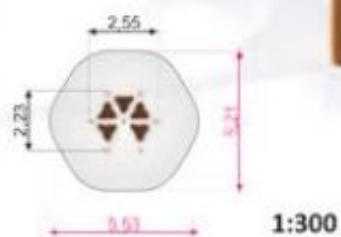
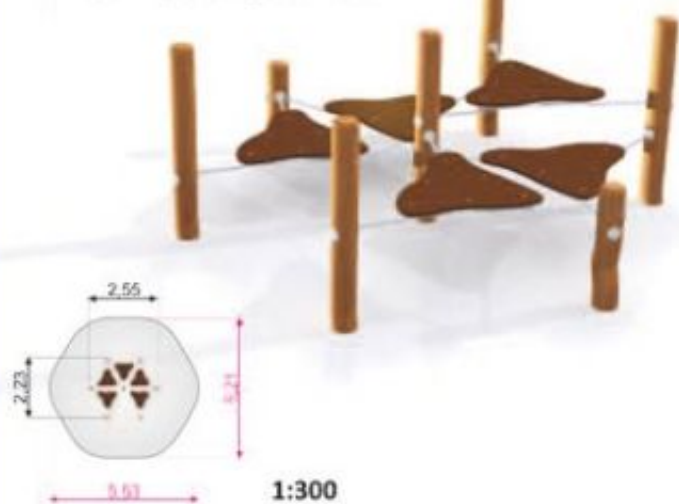

WHITE ROBINIA

13508 BALANCE SYSTEM NATURE

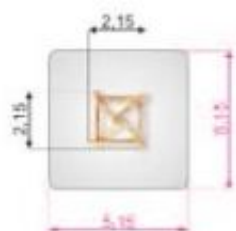

13509 NATURE SYSTEM BALANCE

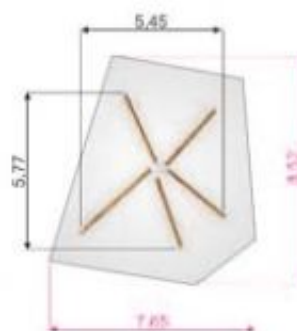

13019

BIKE



3+ 0,78 m 0,50 m 1 h

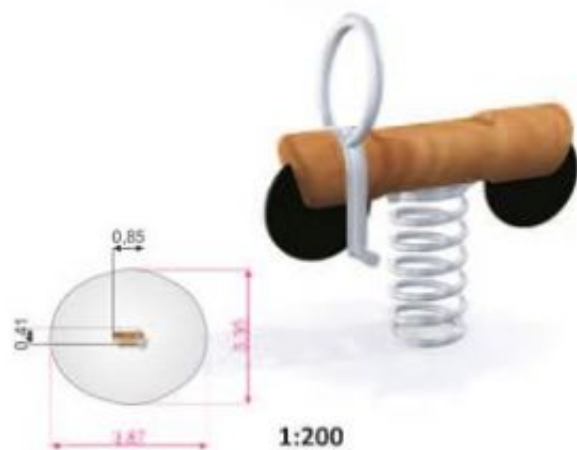

13008

RAMP



3+ 0,55 m 0,55 m 2 h

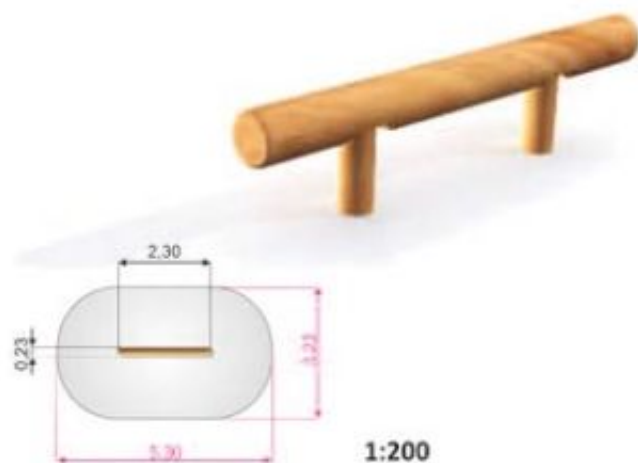

13009

RAMP



3+ 0,55 m 0,55 m 1,5 h

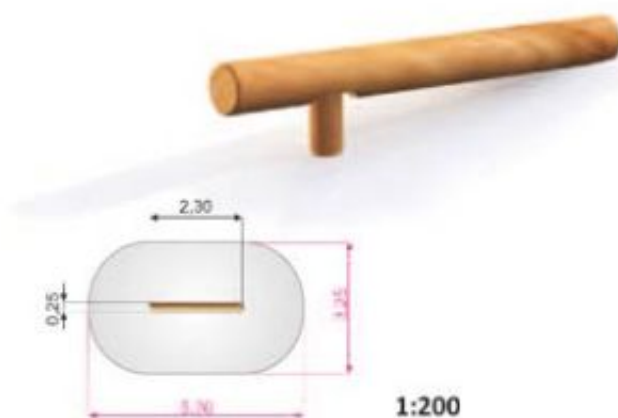

13018

BALANCE



3+ 0,57 m 0,57 m 1,5 h

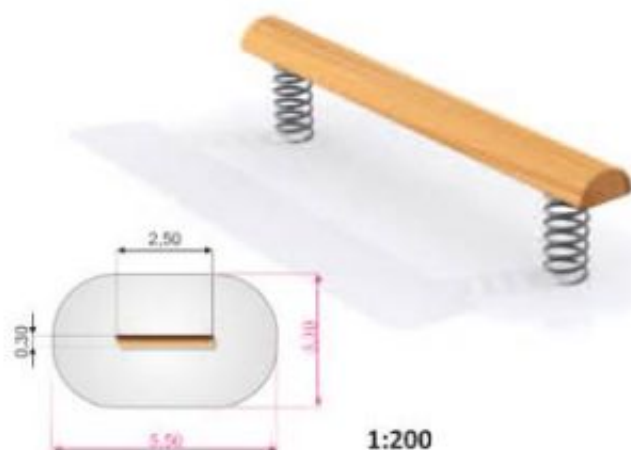

13500

CAPE COD (5 PCS SET)



3+ 0,25-0,55 m 0,55 m 2,5 h

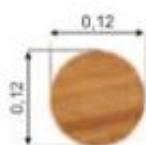

1:10



13501

MADAGASCAR (5 PCS SET)



3+ 0,25-0,55 m 0,55 m 2,5 h

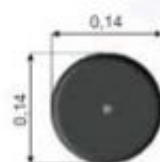

1:10

13545

HORIZONTAL LADDER NATURE



3+ 2,10 m 2,05 m 3,5 h

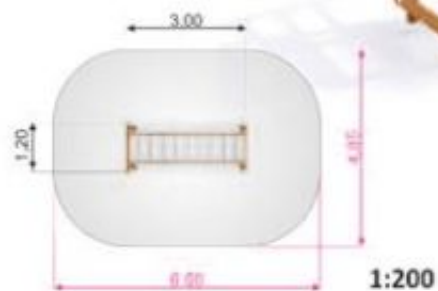

1:200

13010

WOODEN STAIR



3+ 0,20 m 0,20 m 1,5 h



1:200





13540
DOLOMITI

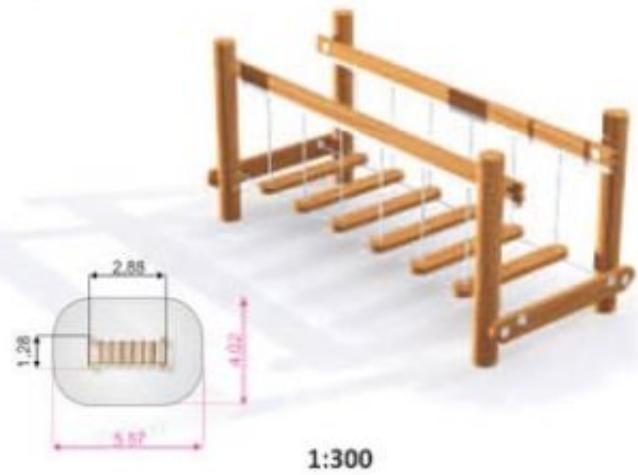

13542
SNOWDONIA

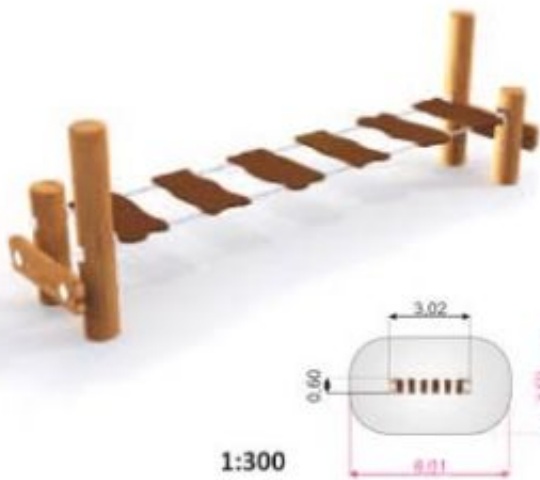

13544
ALASKA

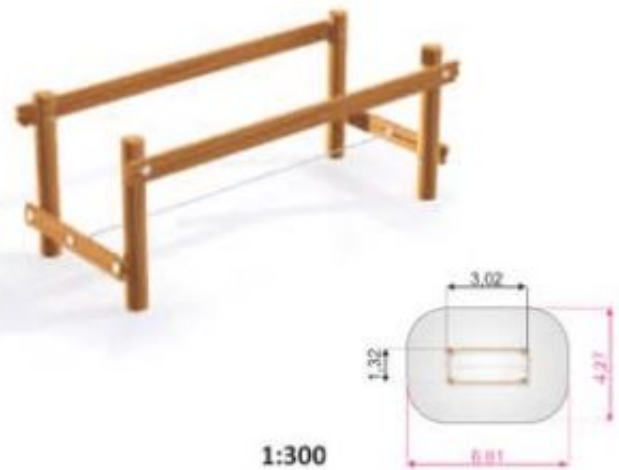

13541
SINTRA

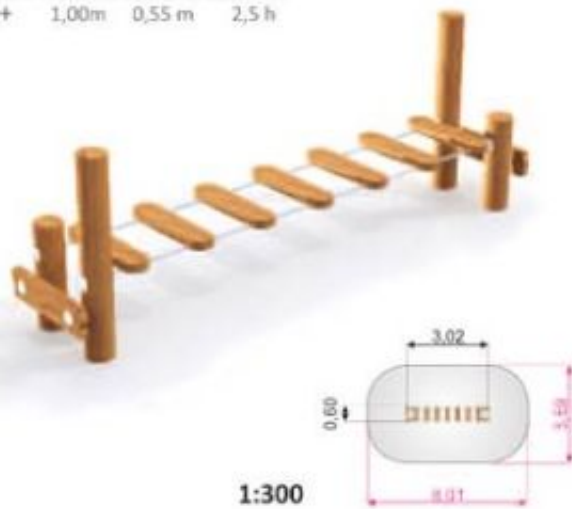

13561

SINGLE SOMERSAULT



3+ 1,00 m 0,95 m 1,5 h

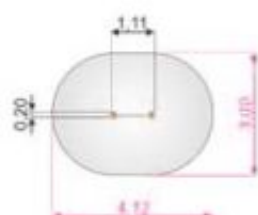

1:200

13571

BAMBOO



3+ 2,10 m 0,30 m 2,5 h

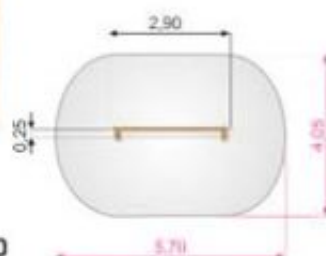

1:200

13562

DOUBLE SOMERSAULT



3+ 1,00 m 0,99 m 2 h

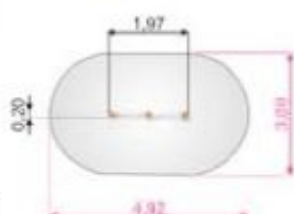

1:200

13563

TRIPLE SOMERSAULT NATURE



3+ 1,20 m 1,14 m 2,5 h

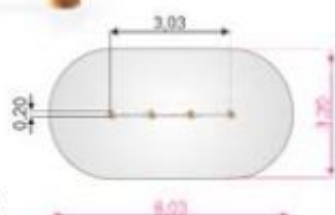
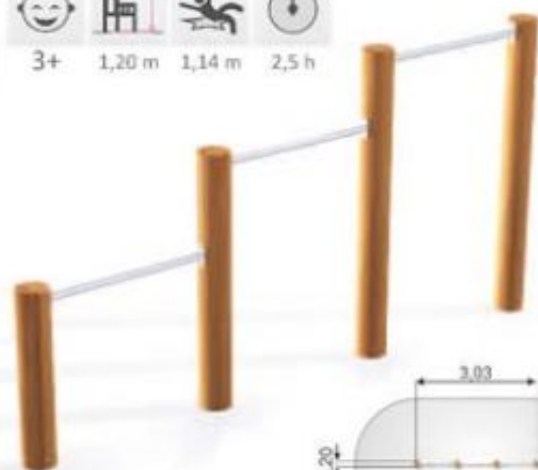

1:200





13570

BARREL

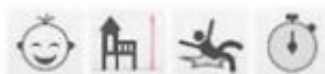

3+ 2,10 m 0,35 m 2 h

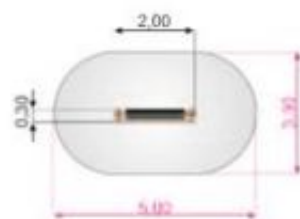

1:200



13543

KONGO



3+ 1,30 m 0,35 m 3 h

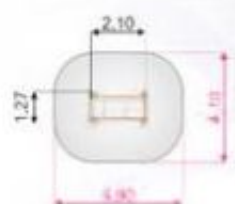

1:300



13572

LIANES



3+ 2,10 m 2,10 m 2 h

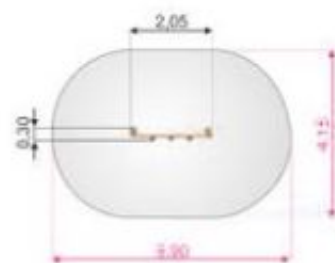

1:200



13604
GOSSAMER

-  3+
-  1,50 m
-  1,35 m
-  5,5 h

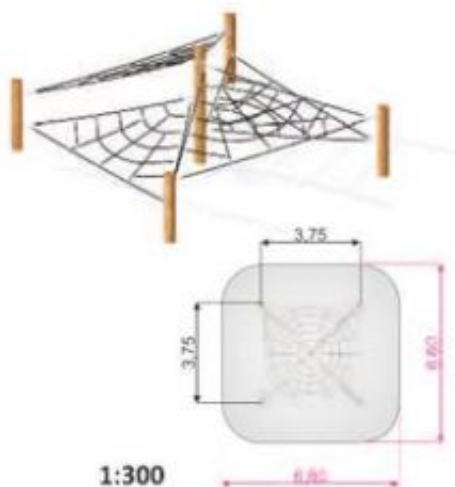

13600
DIAMOND NET

-  3+
-  1,90 m
-  0,90 m
-  2,5 h

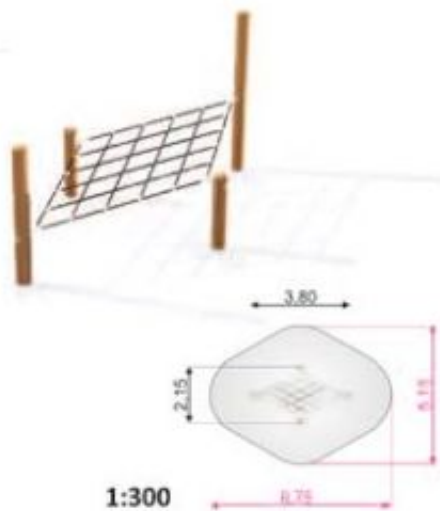

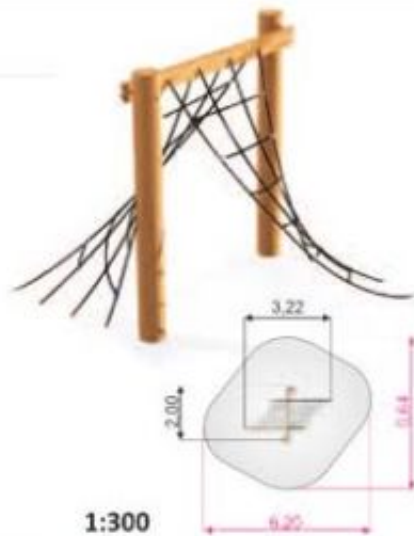

13601
SWALLOW NET

-  3+
-  2,10 m
-  2,00 m
-  5 h





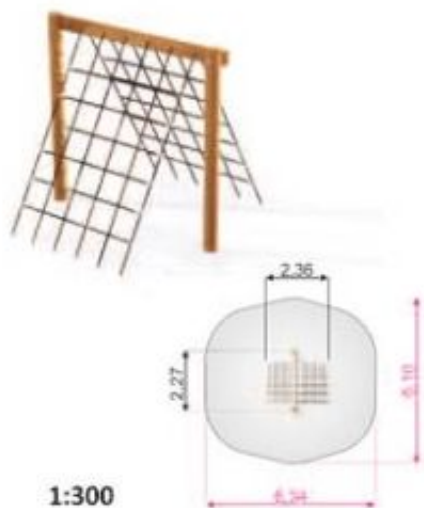

13602
BUTTERFLY NET

-  3+
-  2,10 m
-  2,05 m
-  5 h



13603
MOUNTAINS NET

-  3+
-  2,10 m
-  2,06 m
-  7,5 h

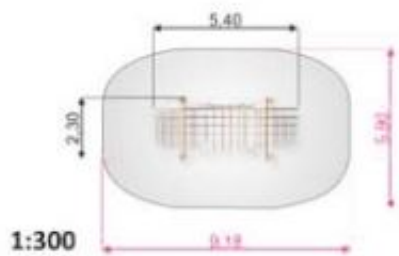

13650
SAHARA

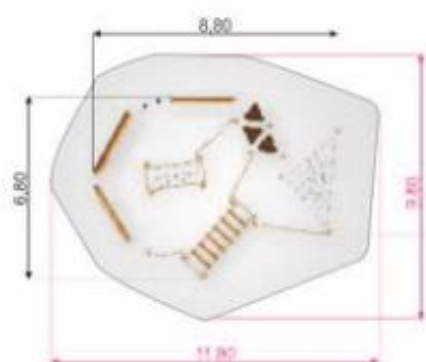

1:300



- 3+
- 1,30 m
- 0,57 m
- 16 h



13651
GOBI

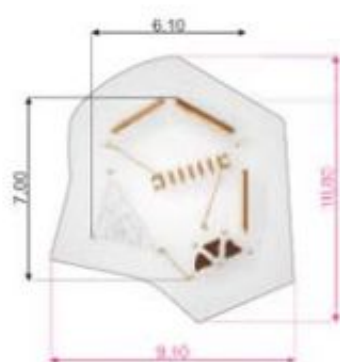

1:300



- 3+
- 1,00 m
- 0,57 m
- 14 h

NATURE TRIM TRAIL COMBINATION



WONDERLAND



12170 STARFISH

-  3+
-  1,96 m
-  0,97 m
-  9 h

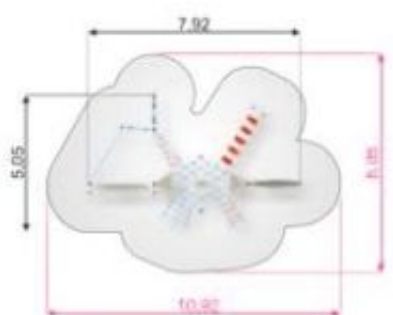

1:300



12270 MINI CLIMBER

-  1+
-  1,02 m
-  1,02 m
-  3 h

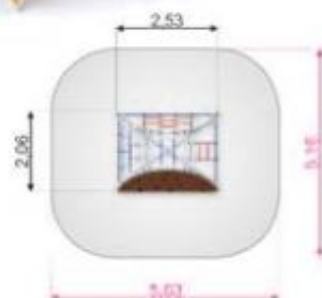

1:200

12250 HIDDEN CORNER

-  3+
-  1,26 m
-  0,97 m
-  2 h

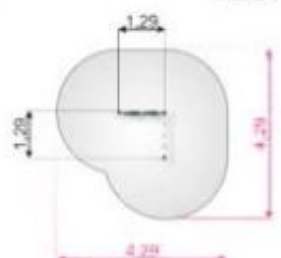

1:200



12173

JUNGLE BRIDGE



3+ 0,48 m 0,48 m 2 h

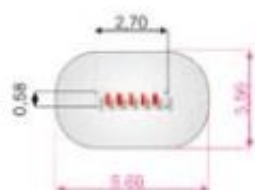

1:300

12172

SURF BOARD



3+ 0,48 m 0,48 m 2 h

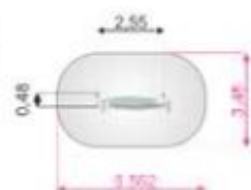

1:300

12171

RHOMBUS NET



3+ 1,97 m 0,97 m 3 h

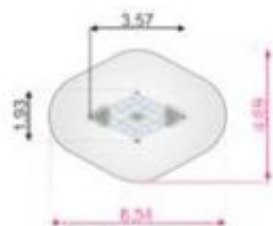

1:300

12174

ACROBAT



3+ 1,20 m 0,45 m 2 h

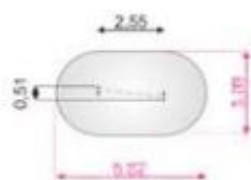

1:300

12177

BALANCES



3+ 1,96 m 0,92 m 2 h

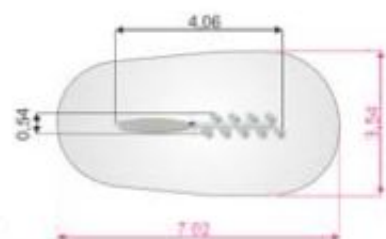

1:200

12240

SEESAW



3+ 0,66 m 0,75 m 2 h

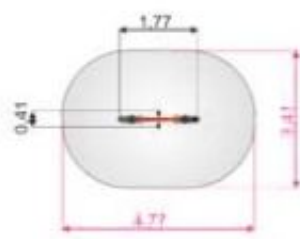

1:200

17121

JUMPING PEGS (5 PCS SET)



3+ 0,15-0,55 m 1,5 h

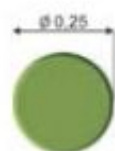

1:20

WONDERLAND TRIM TRAIL COMBINATION



ATLANTIS



12410 JUNIOR

-  3+
-  2,02 m
-  1,20 m
-  2,5 h

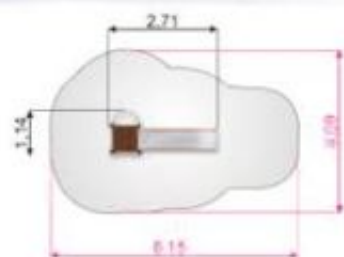

1:200

12415 LADYBIRD

-  3+
-  3,00 m
-  1,20 m
-  3 h

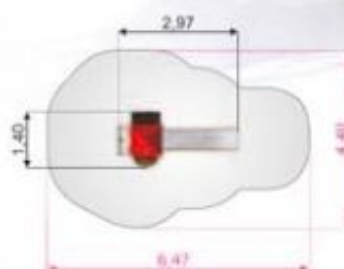

1:200

12420 BEETLE

-  3+
-  3,00 m
-  1,20 m
-  4,5 h

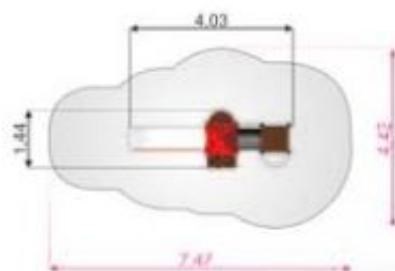

1:200



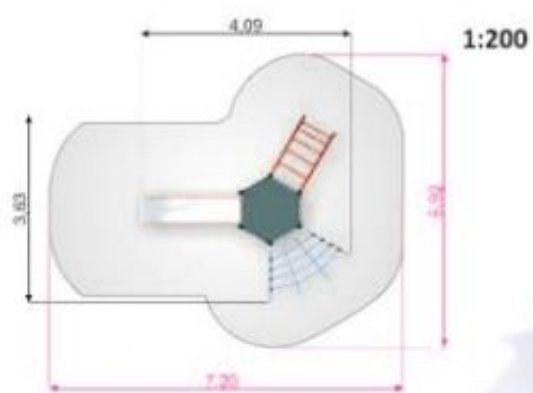

12500
CROW'S NEST



- 3+ 
- 2,06 m 
- 1,20 m 
- 6 h 



12015
MEDUSA

-  3+
-  2,16 m
-  2,00 m
-  4 h

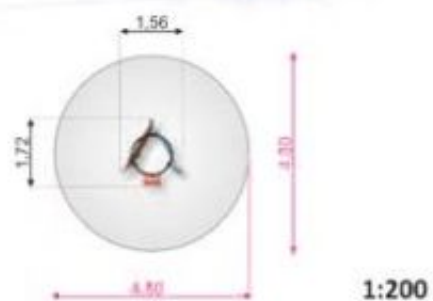

12016
MEDUSA II

- 3+ 
- 2,25 m 
- 2,25 m 
- 4 h 

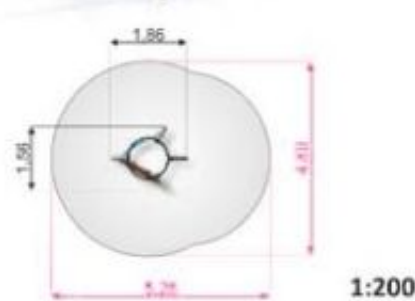

12400
DOLPHIN



3+



2,06 m



1,92 m



8 h

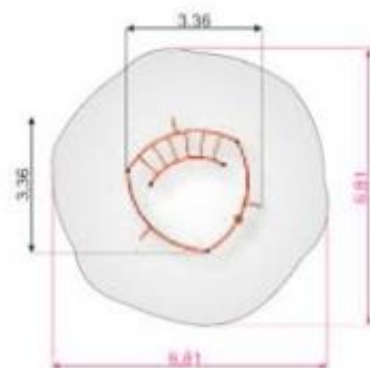

1:200

12425
ORCA



3+



2,06 m



1,92 m



9 h

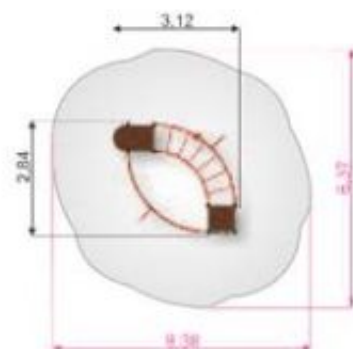

1:200

12426
WHALE



3+



2,06 m



1,92 m



10,5 h

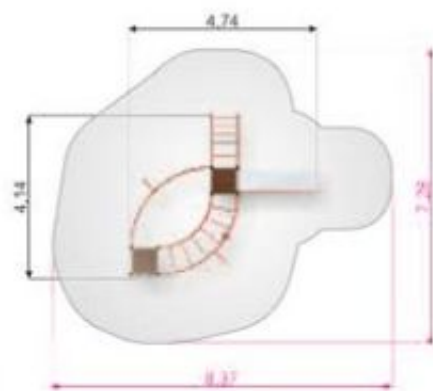

1:200



12436
WHALE - AZTEC

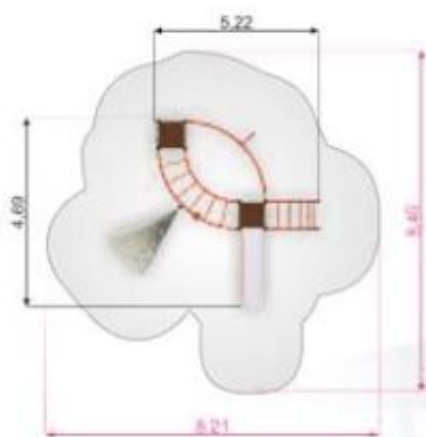

1:200



- 3+ 
- 2,47 m 
- 2,36 m 
- 10,5 h 

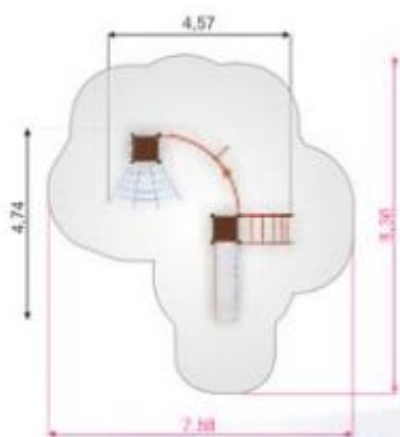

1:200



12427
SWORD FISH

- 3+ 
- 2,06 m 
- 1,92 m 
- 10,5 h 

12431

SPIDER



3+



3,00 m



1,37 m



8,5 h

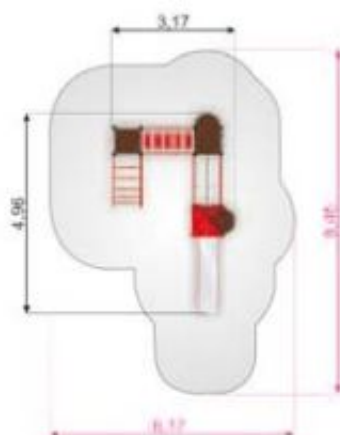

1:200



12430

BUTTERFLY



3+



3,00 m



1,92 m



11 h

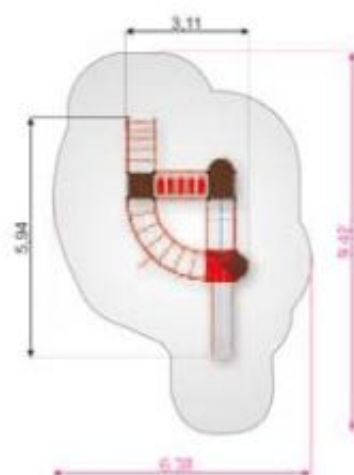

1:200

11361 SINGLE SOMERSAULT

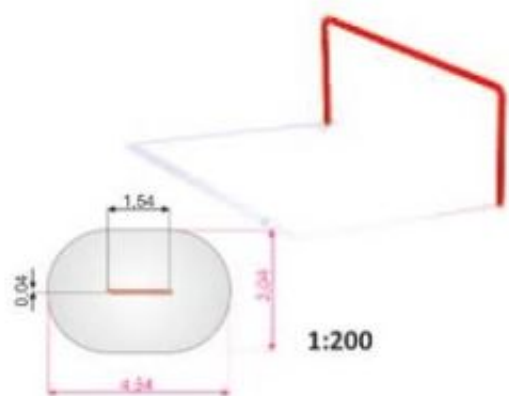
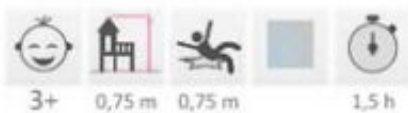

11362 DOUBLE SOMERSAULT

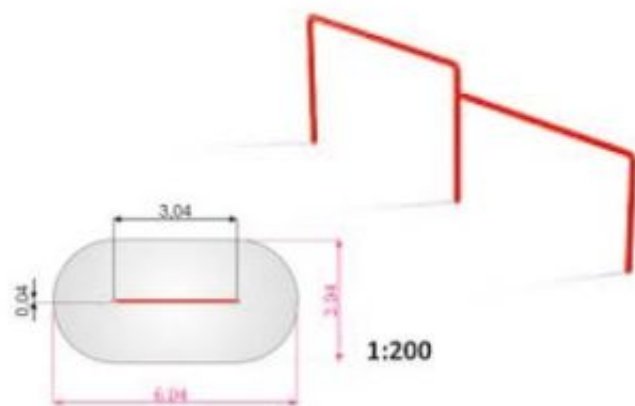

11363 TRIPLE SOMERSAULT

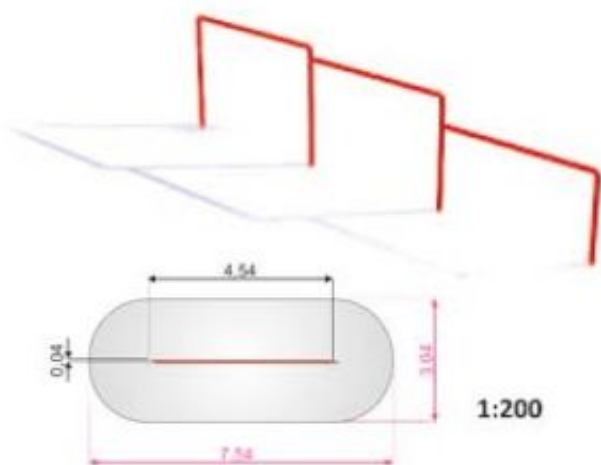

12163 SEESAW

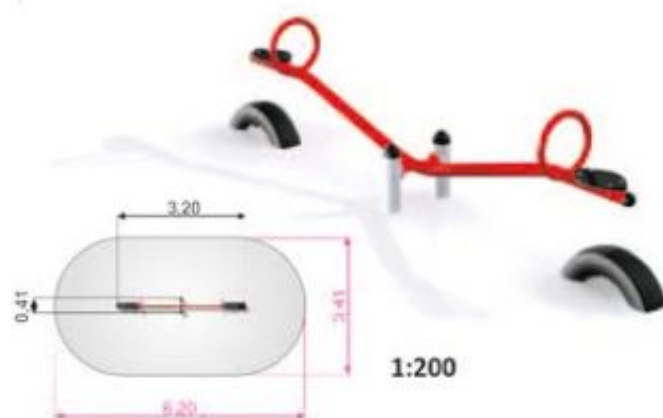

STAND ALONE



11308 CROSS CLIMBER

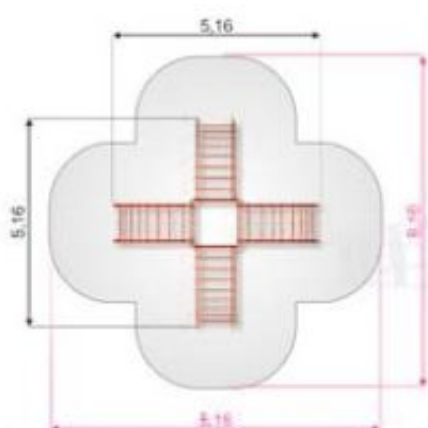

1:200



11309 CROSS CLIMBER

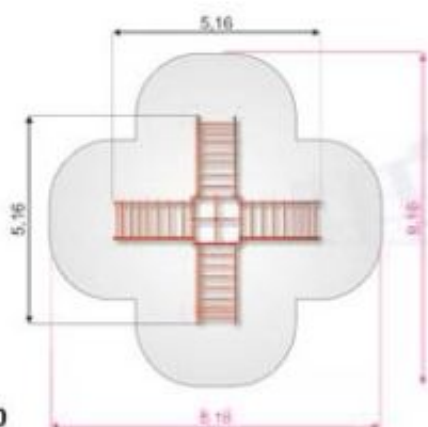

1:200



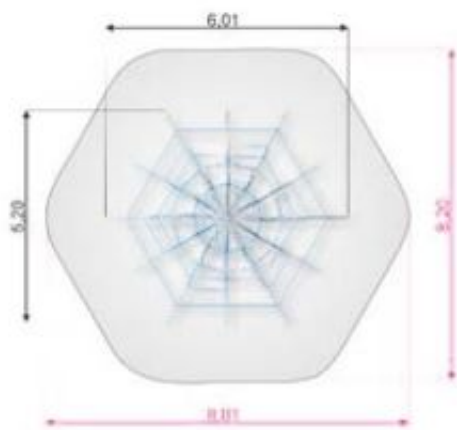

1:200

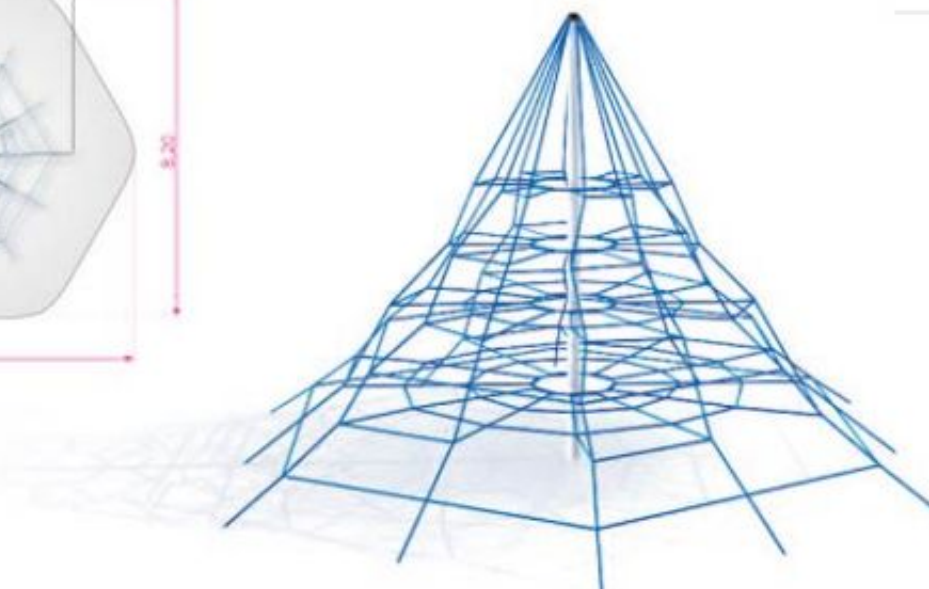

11346
POWERCLIMBER

5+



3,86 m



0,90 m



13 h



11347

MINI POWERCLIMBER



3+



3,35m



0,90 m



10 h

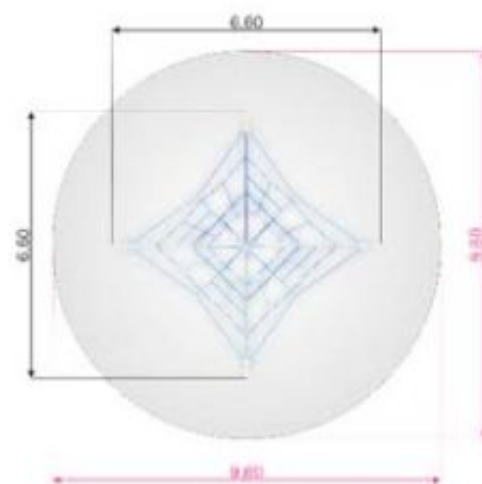
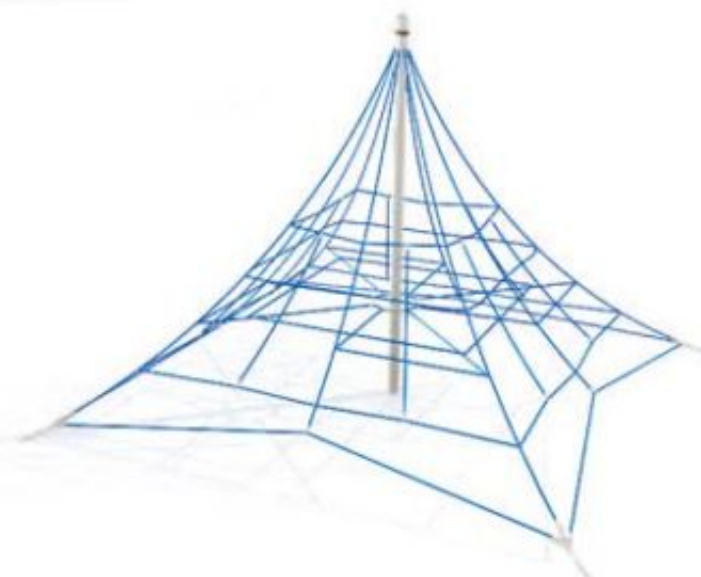

1:200

11304

THE MERRY-GO-ROUND

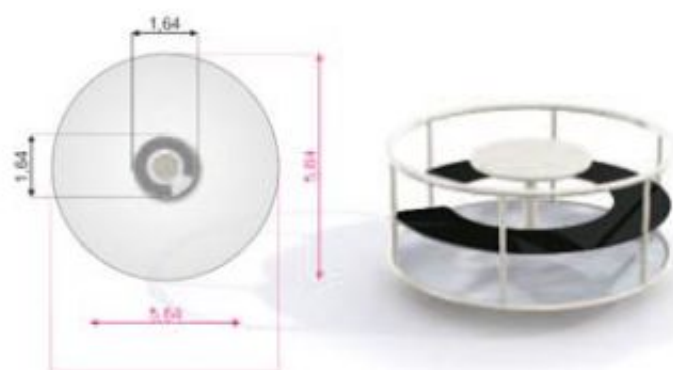

1:300



11307

SPINNING WHEEL

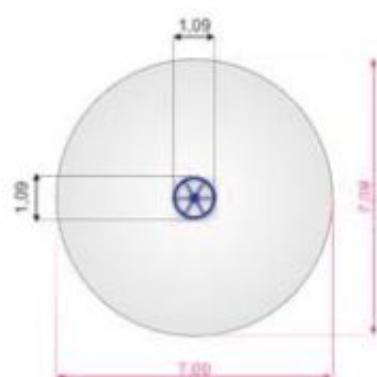

1:200

17231

BLOSSOM



1:200

11330

SLIDE

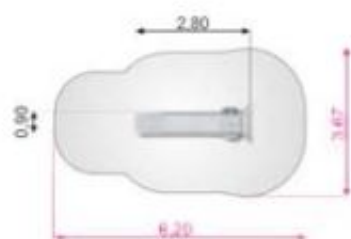

1:200



16130

CUBES

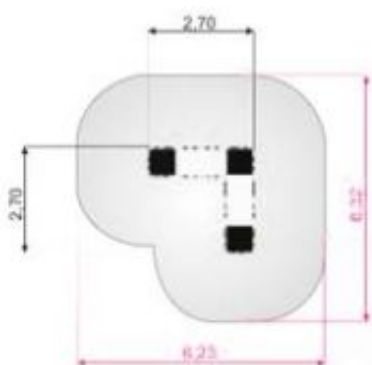

1:200



11351

AZTEC PLAY LOOP



1:200



11350

AZTEC ARCH

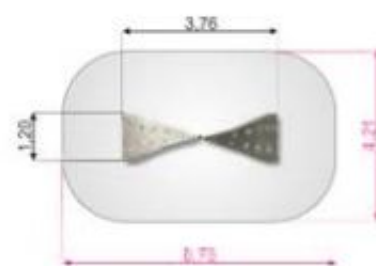

1:200





11301 SPINNER I

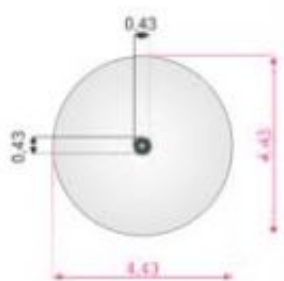

1:200



11302 SPINNER II

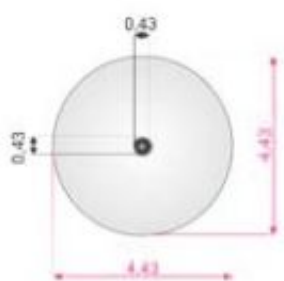

1:200



11303 SPINNER III

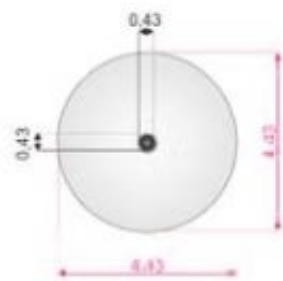

1:200



11305 BEE

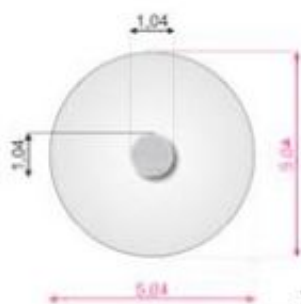

1:200



11322

THE DOUBLE SEESAW



3+ 0,72 m 0,83 m 2 h

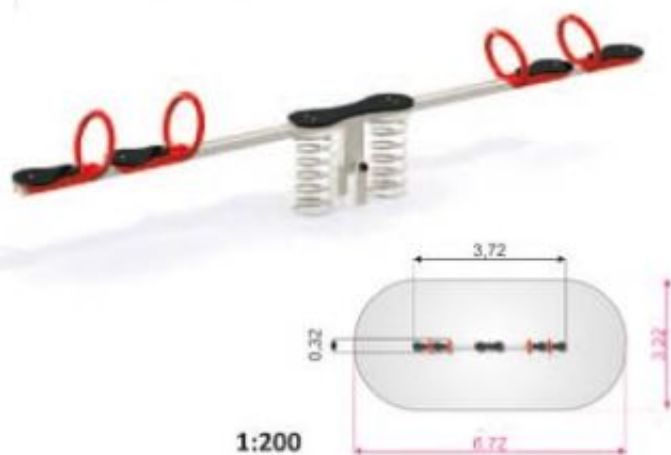

11325

SPRING PLATE



3+ 0,47 m 0,47 m 4 h

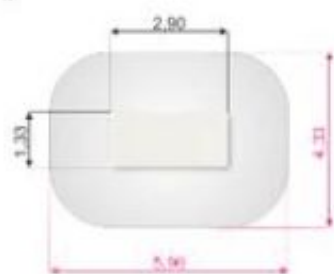

11323

SINGLE SEESAW



3+ 1,13 m 0,96 m 1,5 h

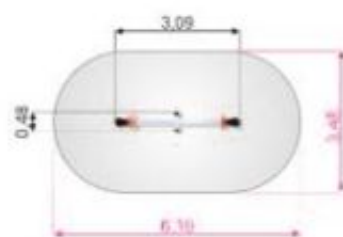

11311

THE MEDIUM CABLEWAY



1:300



5+



2,98 m



0,73 m



7 h



11313

THE SILVER CABLEWAY

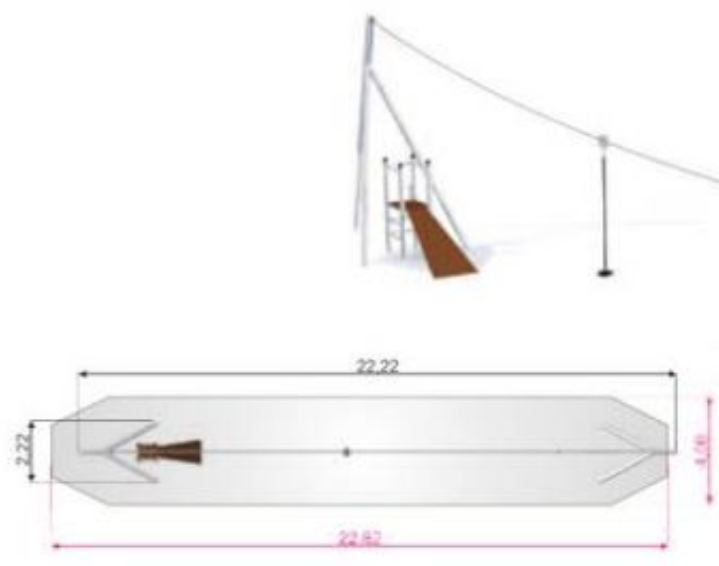

1:300

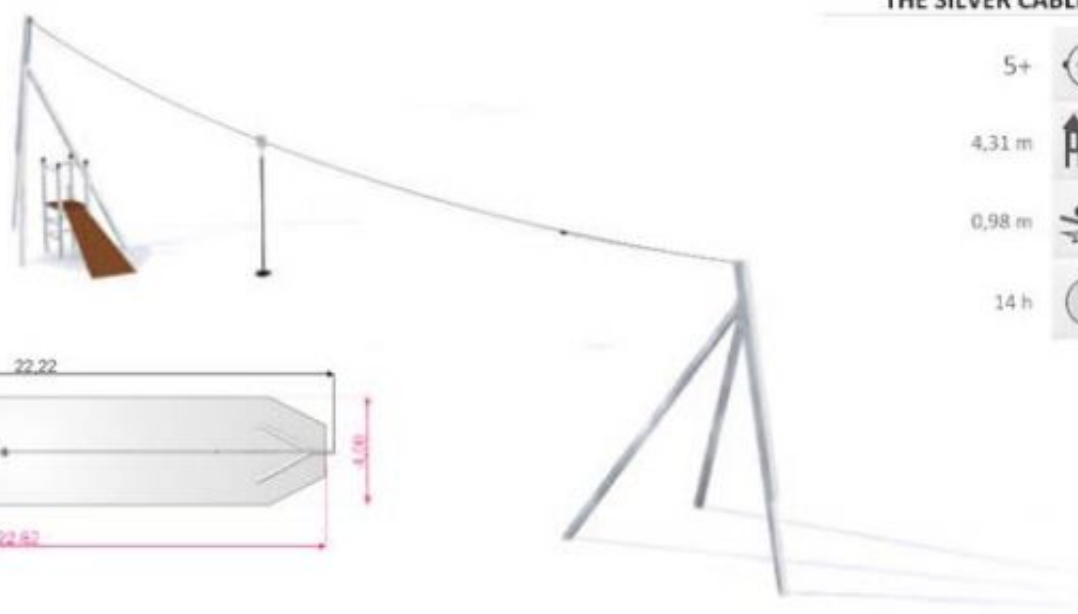

5+



4,31 m



0,98 m



14 h



SOLARIS



17331

ANDROMEDA



3+ 2,60 m 2,42 m 19 h

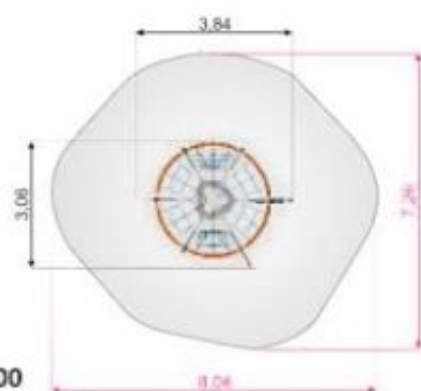

1:200



17323

SIRIUS



3+ 2,46 m 2,40 m 19 h

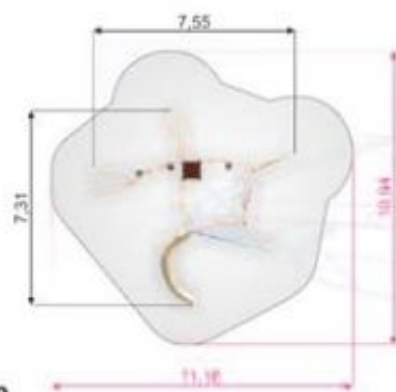

1:300



17120

SPOCK



3+ 0,73 m 0,86 m 2 h

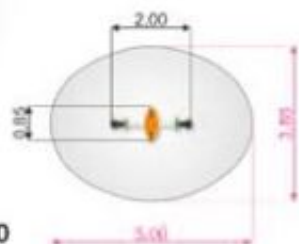

1:200

17220

ET



3+ 0,62 m 0,70 m 2 h

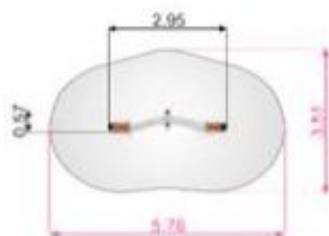

1:200

17130

QUARK



3+ 0,73 m 0,86 m 2 h

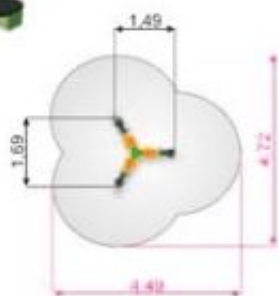

1:200

11306

FLYING SAUCER



5+ 0,58 m 0,58 m 2,5 h

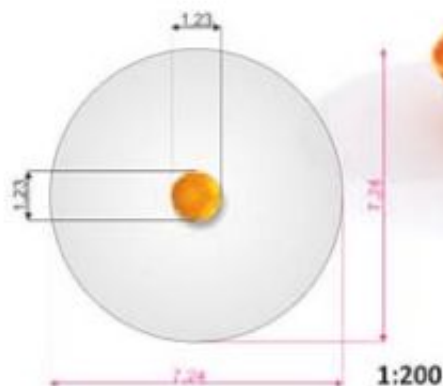

1:200

17140

ALIEN



3+ 0,73 m 0,86 m 2 h

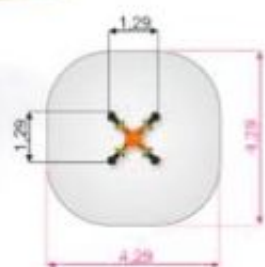

1:200

17300

CAROUSEL



3+ 0,74 m 0,74 m 2,5 h

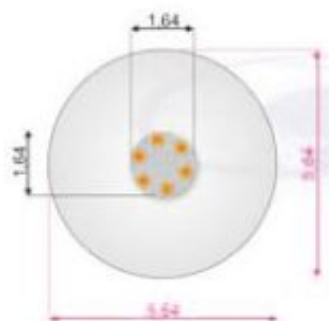

1:200

STREET SPORT



11513 ALLIANZ ARENA



A: 5,05 m 1,81 m 12 h
B: 8,11 m



11501 SANTIAGO BERNABEU



A: 18,20 m 3,66 m 34 h
B: 24,09 m

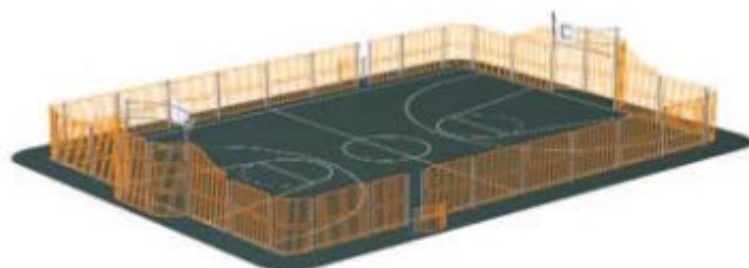

11504 PARC DE PRINC



A: 18,34 m 3,66 m 28 h
B: 24,09m



11505 SAN SIRO



A: 18,20 m 3,66 m 34 h
B: 24,10m



11502 NOU CAMP



A: 15,80 m 3,55 m 38 h
B: 22,10 m

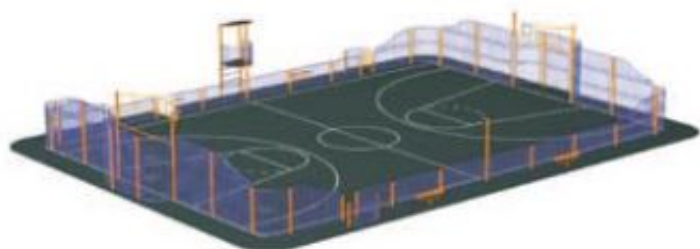

11503 SHEA



A: 16,80 m 3,66 m 31 h
B: 19,10 m

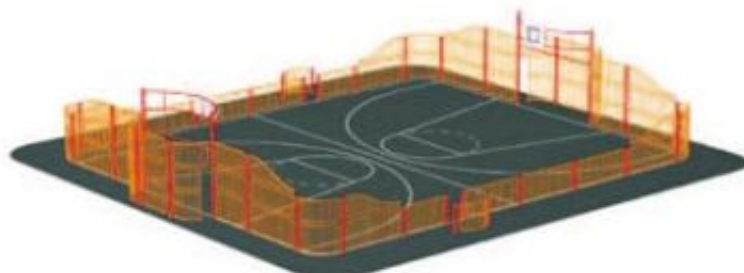

11510 MARACANA



A: 30,50 m 3,66 m 58 h
B: 30,50 m



11635

SMALL ARENA HPL



A: 7,28 m 1,09 m 25 h
B: 13,41 m

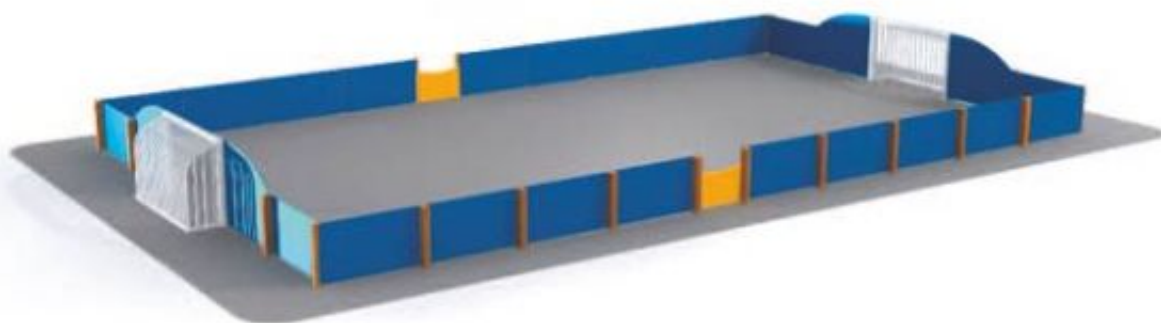

11630

MEDIUM ARENA HPL



A: 7,81 m 2,60 m 25 h
B: 13,95 m

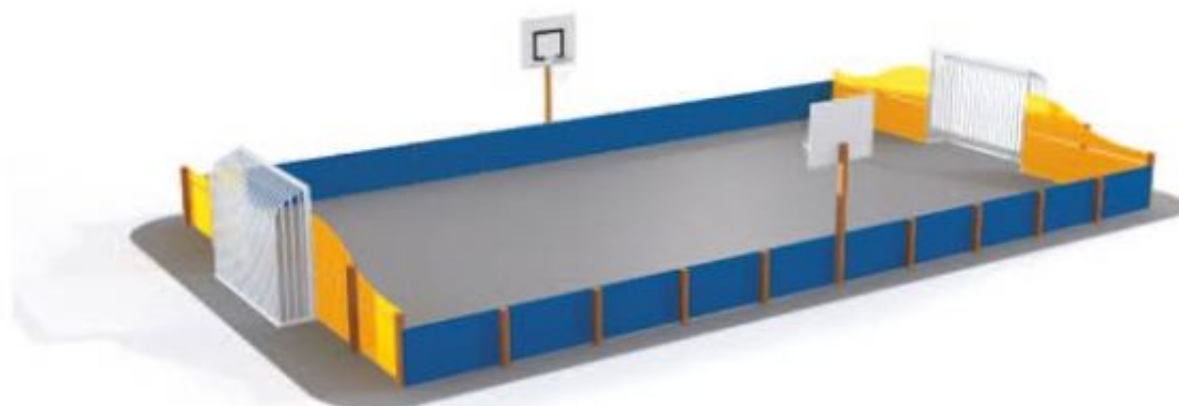

11566 WEMBLEY



A: 20,00 m 3,00 m 46 h
B: 39,00 m

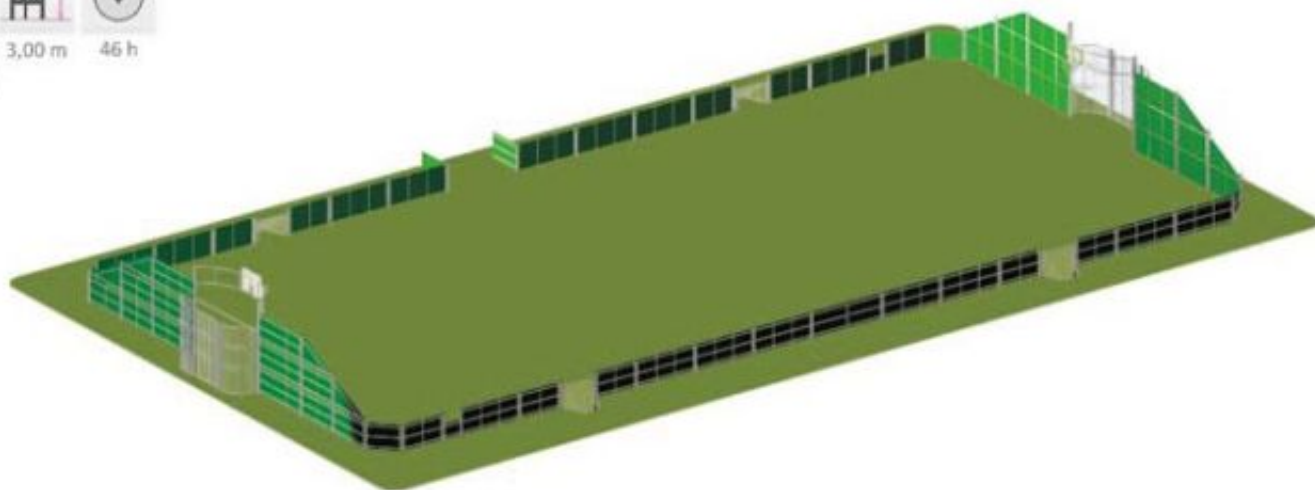

11567 SAINT JAMES



A: 19,00 m 3,26 m 29 h
B: 36,00 m

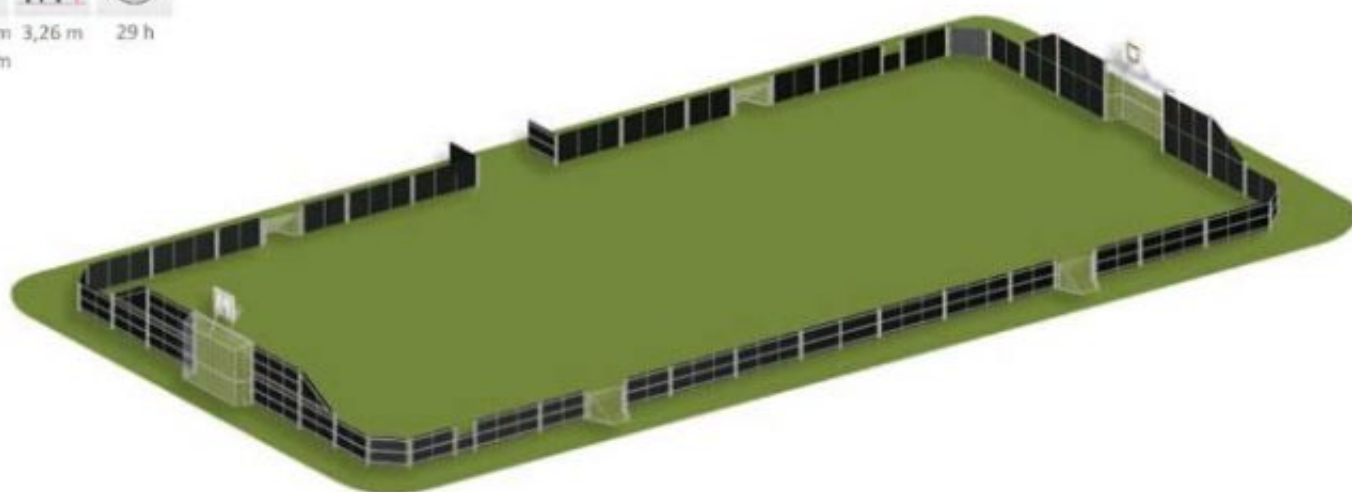

11565 HIGHBURY



A: 8,19 m 2,10 m 17 h
B: 13,62 m



11563 MINIARENA OCTAGONAL I



A: 6,13 m 0,84 m 11 h
B: 8,12 m



11564 MINIARENA OCTAGONAL II



A: 6,93 m 1,09 m 13 h
B: 9,69 m



INSIDEOUT MULTIARENA



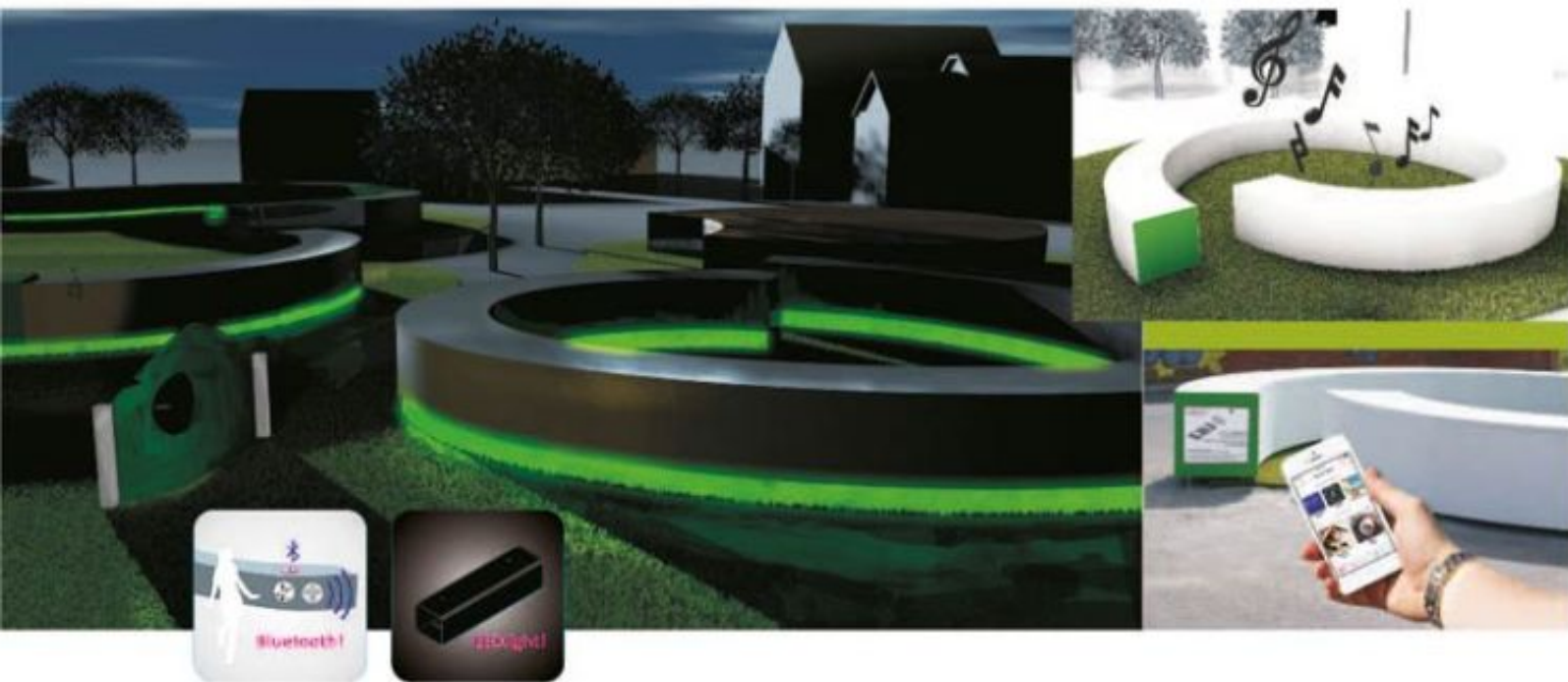

ELEMENTS

BASIC



99060
BOX STRAIGHT CONCRETE



99050
BOX CURVED R4819 CONCRETE



99055
BOX CURVED R2777 CONCRETE



99070
BOX STRAIGHT LARCHWOOD



99075
BOX CURVED R4819 LARCHWOOD



99080
BOX CURVED R2777 LARCHWOOD



99065
BOX STRAIGHT STEEL



99201
BOX ENDING STEEL



99202
BOX ENDING LARCHWOOD



For BOX in steel and concrete.

99060-1
BENCH CONCRETE STRAIGHT



99050-1
BENCH CONCRETE CURVED R4819



99055-1
BENCH CONCRETE CURVED R2777

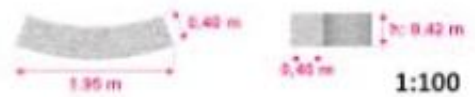

99155
BUILT-IN MUSIC BOX



99150
SCENE

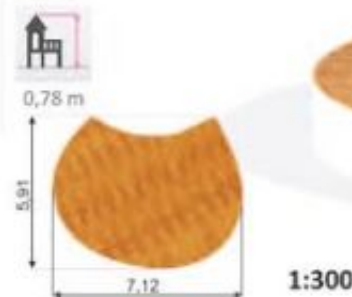



11802
MULTIARENA



4,00 m
BOX H: 0,78 m



1:400

99110

FENCE SECTION CURVED



4,00 m



99115

FENCE SECTION STRAIGHT



4,00 m



11803
MULTIARENA



4,00 m
BOX H: 0,78 m

1:400



11804
MULTIARENA



4,00 m
BOX H: 0,78 m

1:400



11800

MULTIARENA



BOX H: 0,78 m

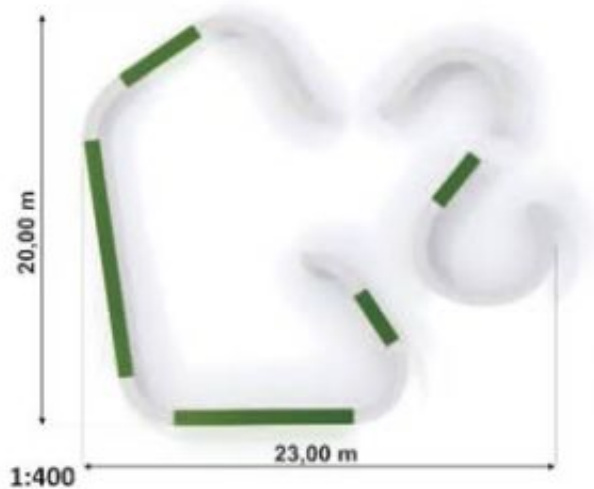
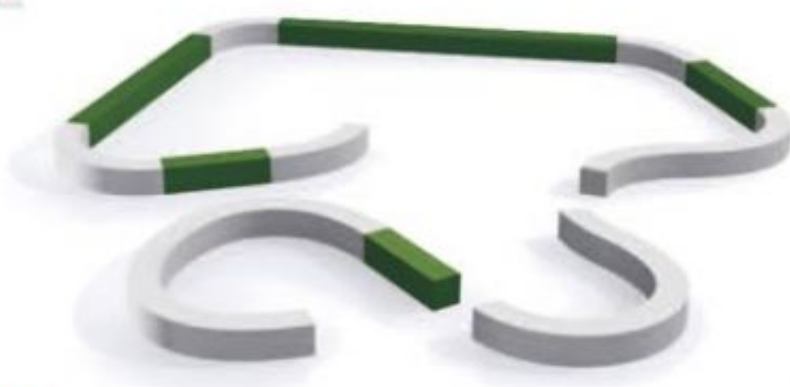

11801

MULTIARENA



4,00 m
BOX H: 0,78 m

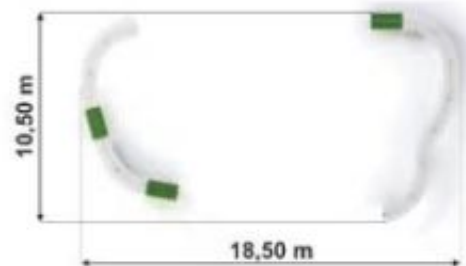
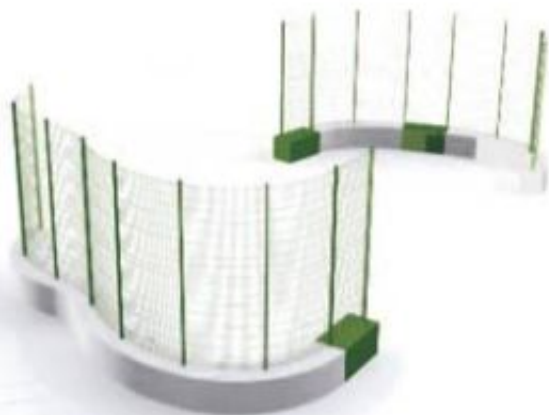

1:400

17144

RAMP



A: 1,00 m 1,00 m 2 h
B: 4,02 m



17143

FLIPPER SET 2ST



A: 1,04 m 0,62 m 3,5 h
B: 3,07 m



17135

SHELTER



3,40 m 5 h

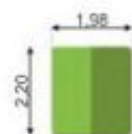

1:200





17147
CONCRETE BOX



17145
PUNCHING BAG

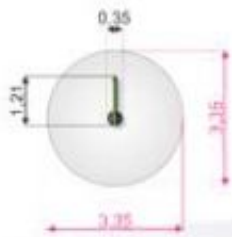

1:200



17150
GOAL



17141
AIM PRACTICE I

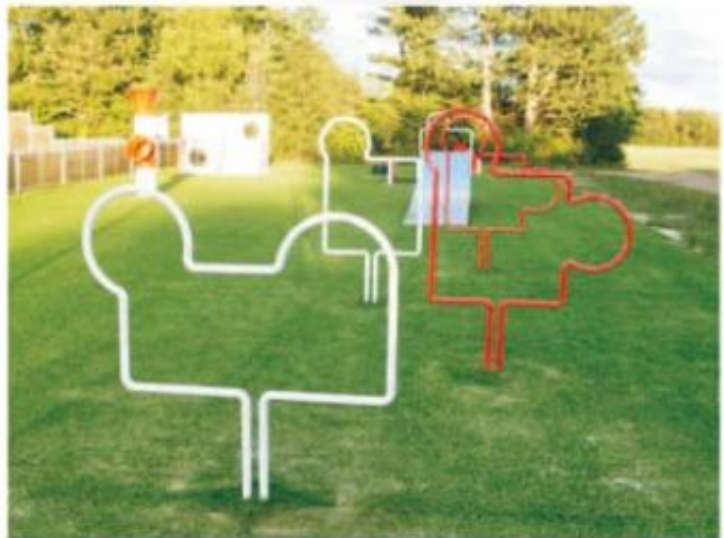

17142
AIM PRACTICE II



17146
BALL CATCHER

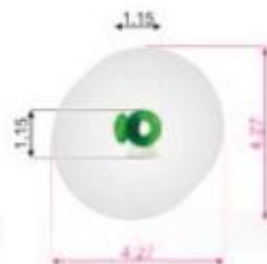

1:200





11522 OLIMPICO

A: 2,75 m
B: 13,90 m

3,66 m

9 h



11523 JORDAN

A: 2,69 m
B: 8,80 m

3,65 m

8 h



11524 MAGIC

A: 2,75 m
B: 8,90 m

3,65 m

8 h

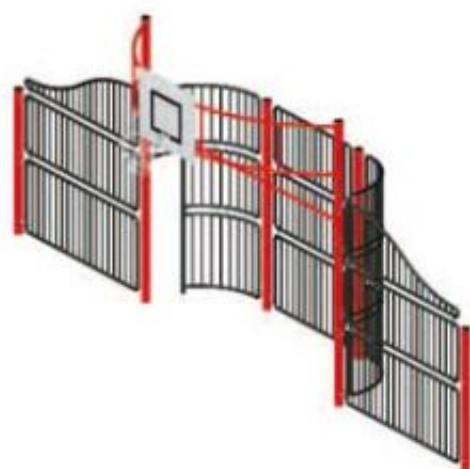

11525 PELE

A: 2,76 m
B: 8,89 m

3,56 m

8 h



11561 GOAL

A: 1,22 m
B: 8,18 m

3,26 m

5 h



11562 GOAL

A: 60 m
B: 5,22 m

1,09 m

4 h



11570

GOAL



A: 0,60 m
B: 3,18 m



3,66 m



2 h



11573

GOAL



A: 0,60 m
B: 1,80 m



3,65 m



1,5 h



11579

MINI GOAL



A: 0,85 m
B: 1,29 m



0,85 m



0,5 h



11600

BASKET



A: 0,76 m
B: 1,10 m



2,60 m



4 h



11500

BASKET



A: 1,10 m
B: 1,76 m



3,66 m



4 h



11601

BASKET ORGANIC



A: 1,80 m
B: 1,20 m



3,66 m



4 h



11610

AIM PRACTICE



A: 1,70 m 3,13 m 2,5 h
B: 4,03 m



11705

OUTDOOR TABLE TENNIS ORGANIC



A: 1,65 m 0,91 m 2 h
B: 2,60 m

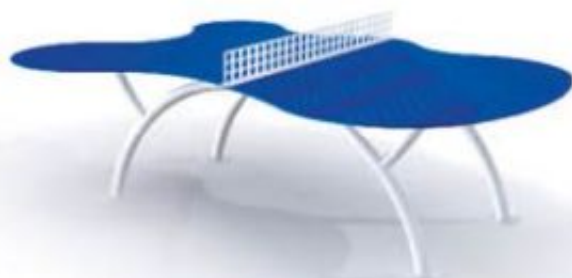

11704

OUTDOOR TABLE TENNIS



A: 1,52 m 0,91 m 2 h
B: 2,60 m



11707

CONCRETE TABLE TENNIS, FREE-STANDING



A: 1,52 m 0,76 m 2,5 h* 740 kg
B: 2,74 m



*Installation time for 4 persons

11708

CONCRETE TABLE TENNIS, IN-GROUND



A: 1,52 m 0,76 m 3 h* 740 kg
B: 2,74 m



*Installation time for 4 persons

SKATE



11781 COMBINATION 8



A: 1,20 m 0,98 m 2850 kg
B: 4,78 m



1:200



11782 COMBINATION 16



A: 2,40 m 0,98 m 5530 kg
B: 4,60 m



1:200



11780 COMBINATION 6



A: 3,08 m 0,98 m 3765 kg
B: 4,60 m



1:200



11789 FUN BOX TYPE 2



A: 4,60 m 0,98 m 7500 kg
B: 5,70 m



1:200





11784
COMBINATION 20

 A: 3,08 m 0,98 m 5685 kg
 B: 5,80 m

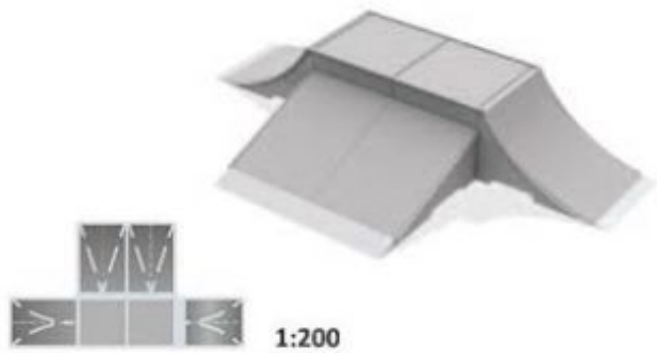

11786
FUN BOX TYPE A

 A: 4,14 m 0,70 m 2500 kg
 B: 4,95 m

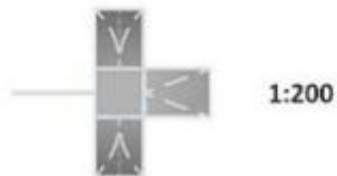

11787
FUN BOX TYPE A

 A: 4,60 m 0,98 m 3770 kg
 B: 5,98 m

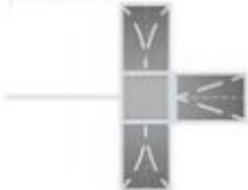

1:200



11785
COMBINATION 21

 A: 3,87 m 0,70 m 7885 kg
 B: 6,16 m

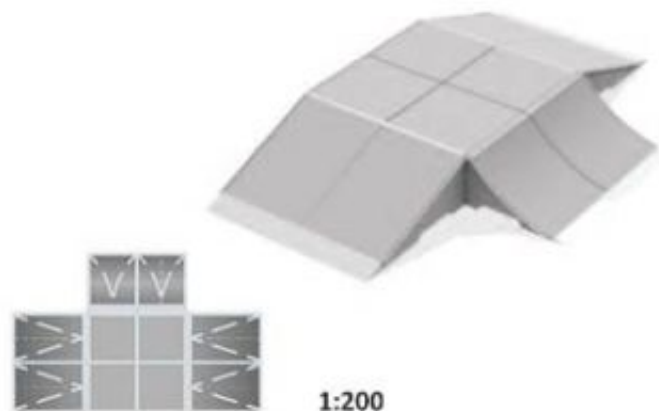

11788
FUN BOX TYPE 1

 A: 5,05 m 0,70 m 8150 kg
 B: 5,34 m

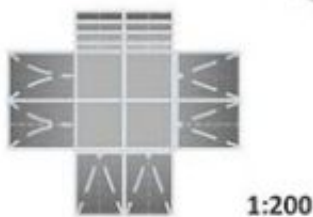
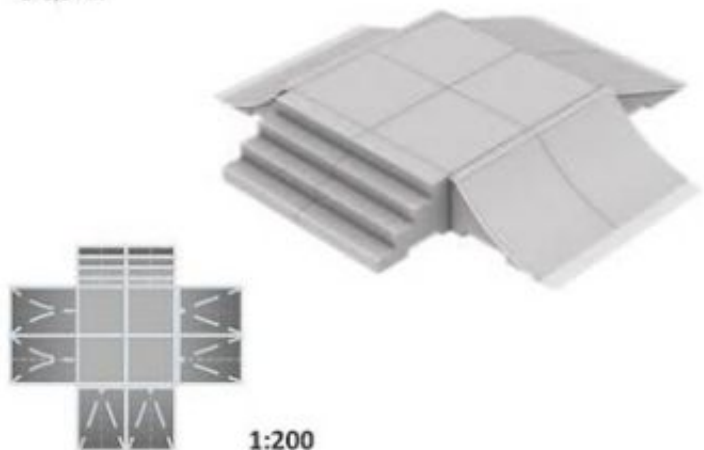

11783

COMBINATION 19



A: 4,50 m 0,70 m 5780 kg
B: 4,87 m

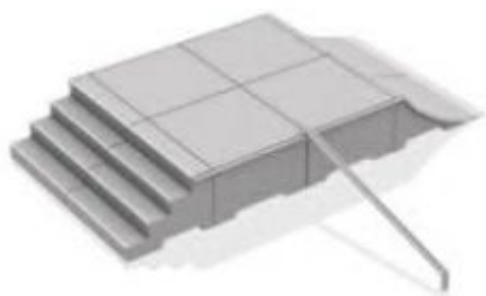

1:200



11741

DOPPEL QUARTER-PIPE



A: 2,40 m 0,70 m 2600 kg
B: 2,67 m

1:200



11743

DOPPEL QUARTER- PIPE



A: 2,40 m 0,98 m 3720 kg
B: 2,90 m

1:200



11731

WALL RAMP



A: 2,40 m 3,00 m 4000 kg
B: 2,25 m



1:200



11790 FUN BOX 13



A: 6,68 m 1,39 m 23000 kg
B: 8,60 m

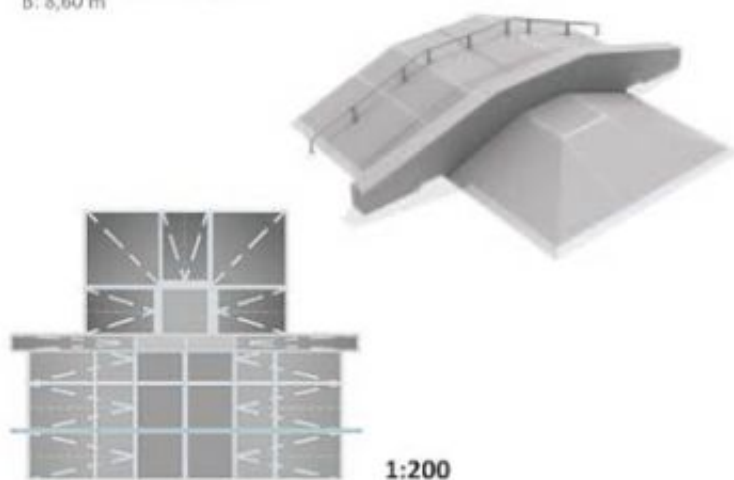

1:200



11791 FUN BOX 27



A: 7,06 m 1,11 m 22430 kg
B: 7,88 m

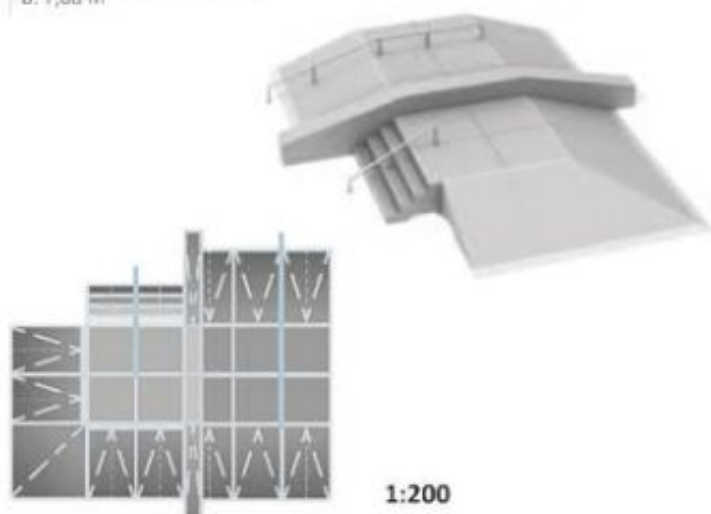

1:200



11792 FUN BOX 6



A: 7,06 m 1,11 m 17360 kg
B: 9,08 m

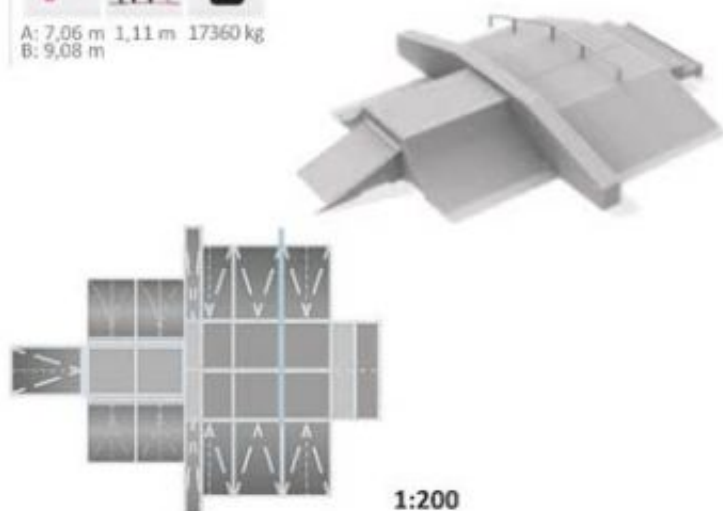

1:200



11701

FUN - RAMP BASIC MODEL

 A: 3,90 m
B: 10,31 m

 2,90 m

 22000 kg

11711

FUN-RAMP BIG

 A: 5,10 m
B: 10,31 m

 2,90 m

 29333 kg

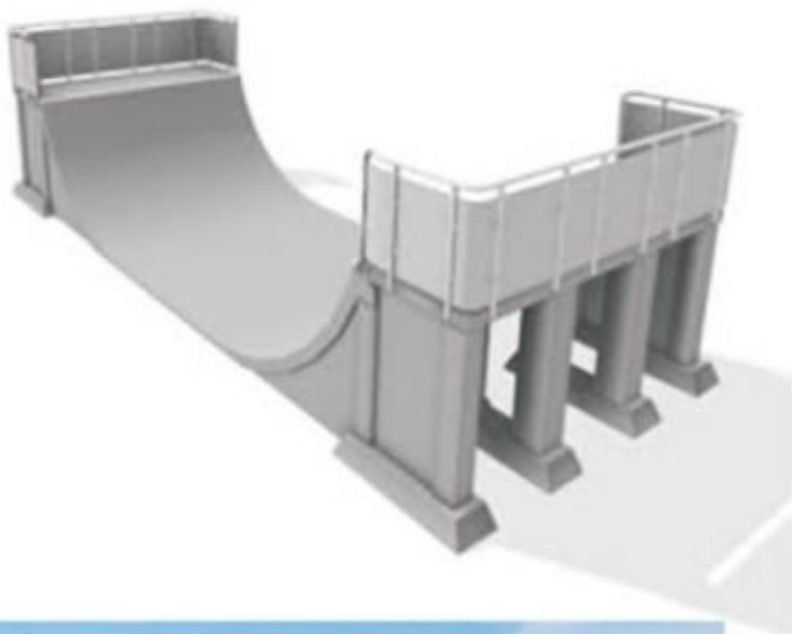

1:300



1:300



11721

QUARTER- PIPE HIGH

A: 4,00 m 2,90 m 9350 kg
B: 3,91 m



1:200

11723

QUARTER-PIPE HIGH WIDE

A: 4,00 m 2,90 m 11960 kg
B: 5,10 m



1:200



11794
QUARTER 3



A: 3,85 m 2,08 m 8750 kg
B: 4,80 m

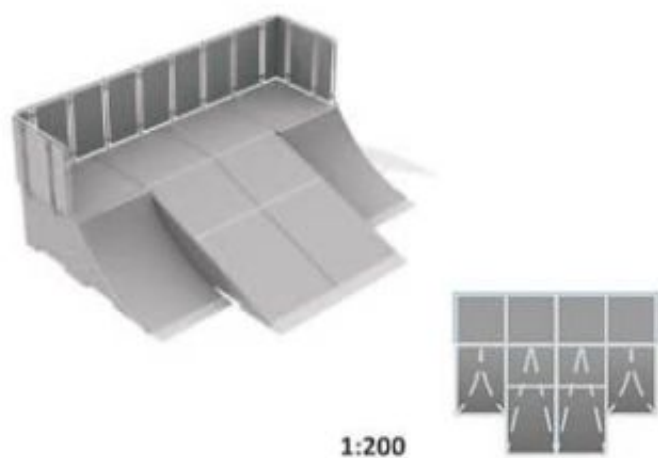

1:200



11793
QUARTER 2



A: 3,70 m 2,08 m 7260 kg
B: 3,85 m

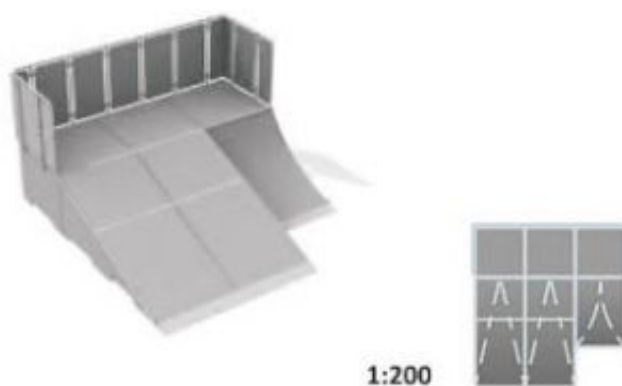

1:200



11795
QUARTER 5



A: 3,85 m 2,08 m 13500 kg
B: 7,20 m

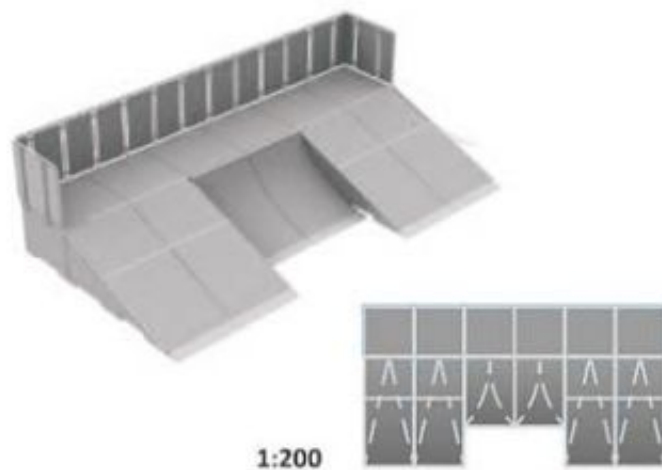

1:200

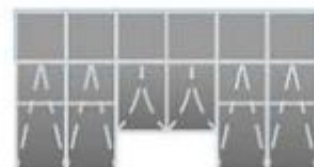

11759

BOX



A: 1,20 m 0,70 m 750 kg
B: 1,20 m



11760

BOX



A: 1,20 m 0,98 m 780 kg
B: 1,20 m



11761

STAIRS



A: 1,20 m 0,70 m 920 kg
B: 1,20 m



11762

STAIRS



A: 1,20 m 0,98 m 1150 kg
B: 1,20 m



11773

BANK



A: 1,20 m 0,60 m 700 kg
B: 1,65 m

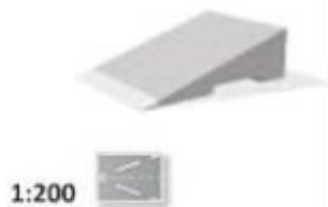

11774

BANK



A: 1,20 m 0,70 m 980 kg
B: 1,88 m

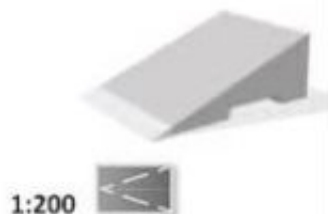

11775

SKATE BANK II



A: 1,20 m 0,98 m 1530 kg
B: 2,67 m



11763

CURB FOR BOX



A: 0,10 m 0,70 m 22 kg
B: 2,10 m



11764

CURB FOR BOX



A: 0,10 m 0,98 m 25 kg
B: 2,90 m

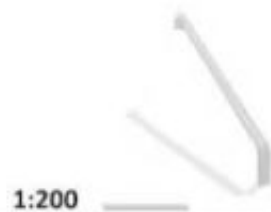

11767

CURB HORIZONTAL



A: 0,23 m 0,15 m 140 kg
B: 2,40 m

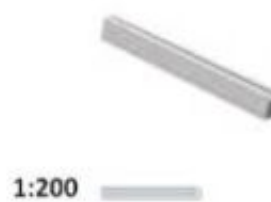

11768

CURB SLOPING- HEIGHT: 15- 25CM



A: 0,23 m 0,25 m 200 kg
B: 2,40 m



11776

CORNER



A: 1,88 m 0,70 m 1010 kg
B: 1,88 m



11777

RAIL 25/60



A: 0,06 m 0,60 m 48 kg
B: 4,80 m

1:200



11778

RAIL 25/60



A: 0,06 m 0,60 m 58 kg
B: 6,00 m

1:200



11770

WALK BOX



A: 1,20 m 0,25 m 940 kg
B: 2,40 m

1:200

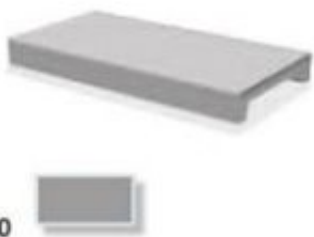

11757

JUMP-RAMP



A: 1,20 m 0,70 m 530 kg
B: 1,47 m

1:200



11771

OLLY BOX 3



A: 1,20 m 0,50 m 1400 kg
B: 2,40 m

1:200



11758

JUMP-RAMP



A: 1,20 m 0,98 m 910 kg
B: 1,68 m

1:200



11772

BIG OLLY-BOX



A: 2,40 m 0,50 m 2270 kg
B: 2,40 m

1:200



11755

SPINE-RAMP



A: 1,20 m 0,80 m 1070 kg
B: 2,94 m

1:200



OUTDOOR FITNESS



MILITARY FITNESS

10684 CLIMB OBSTACLE



1,80 m 1,80 m 4,5 h

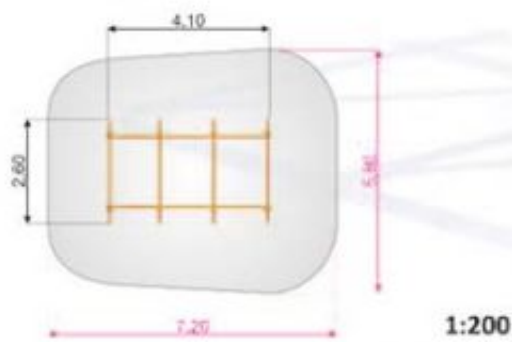

1:200



10690 BALANCE



0,35 m 0,28 m 2,5 h

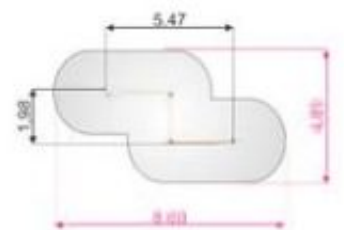

1:300



10681
EASY BALANCER

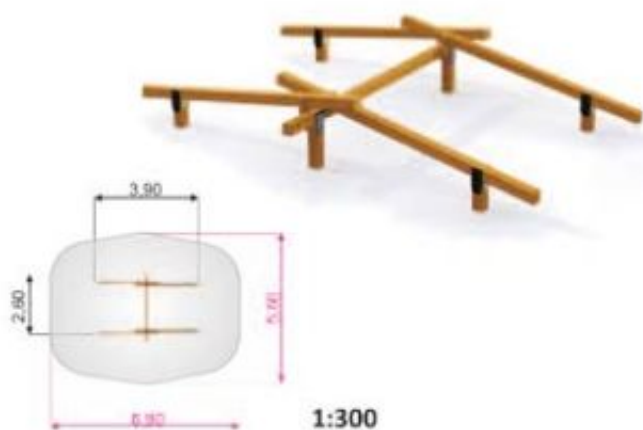

10683
HIP HOP

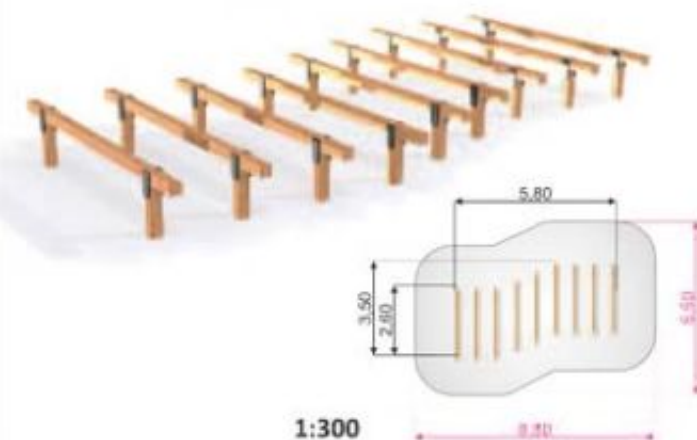

10687
TIRES (10 PCS)



10682

DOUBLE JUMP BARS



1,02 m



1,02 m



W2W



2,5 h

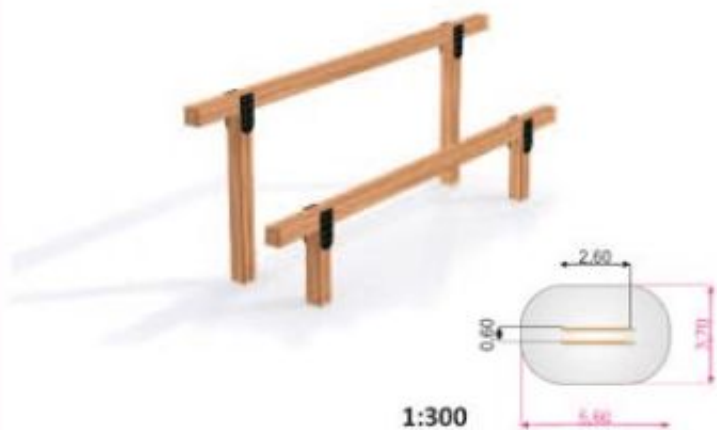

10689

V-SHAPE NET LARGE



3,06 m



2,97 m



W2W



5 h

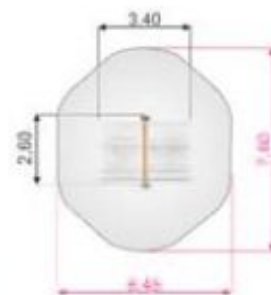

1:300



10688
HORIZONTAL LADDER LARGE

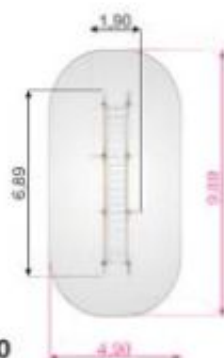

1:300

10685
STEP AND CLIMB

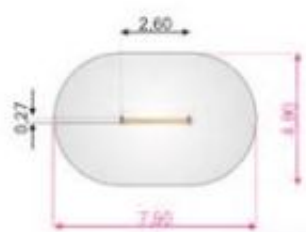

1:300



OUTDOOR FITNESS



WOODEN FITNESS

10691 PULL BAR

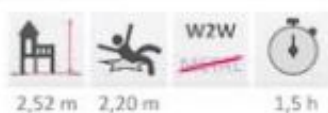

2,52 m 2,20 m 1,5 h

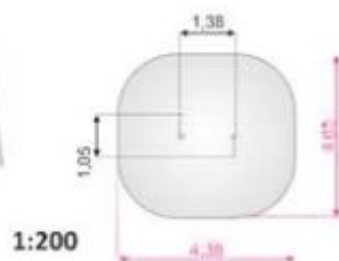

10697 PLATFORM 90



1,18 m 1,18 m 2 h

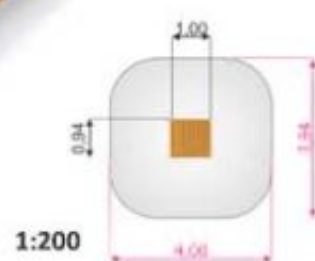

10698 PLATFORM 180



0,18 m 0,18 m 2,5 h

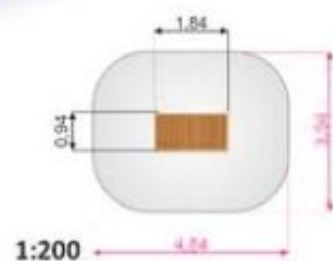

10692 PULL BARS

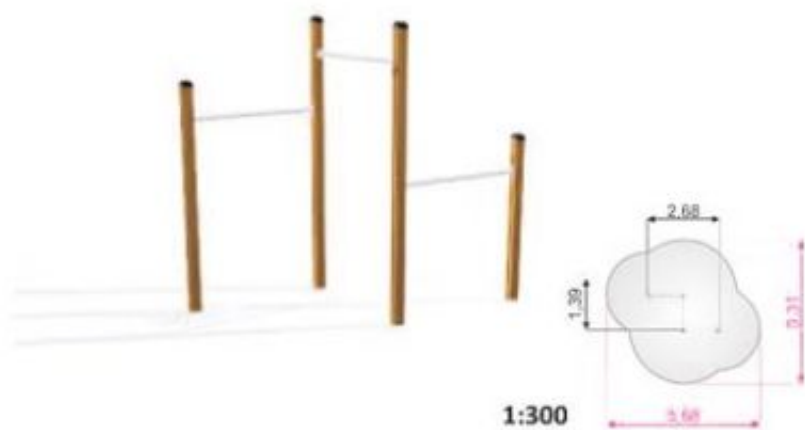
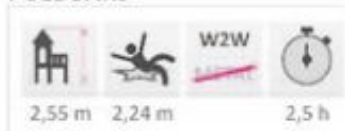

10696 HANDLES



10694 BARS I

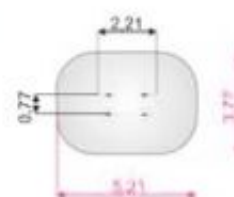
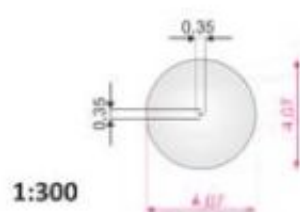

10695 BARS II

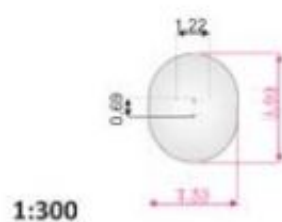



10835 STRETCHING BAR

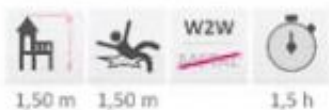

1,50 m 1,50 m 1,5 h

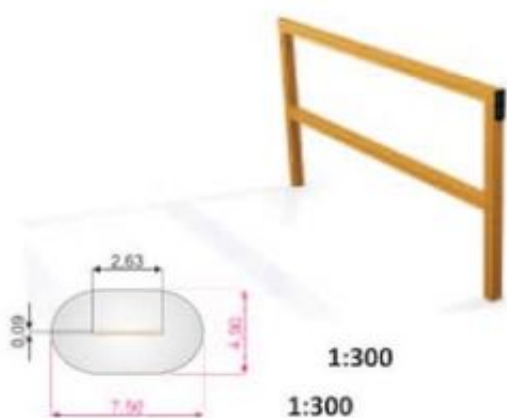

10836 OVER-UNDER



1,50 m 1,50 m 3,5 h

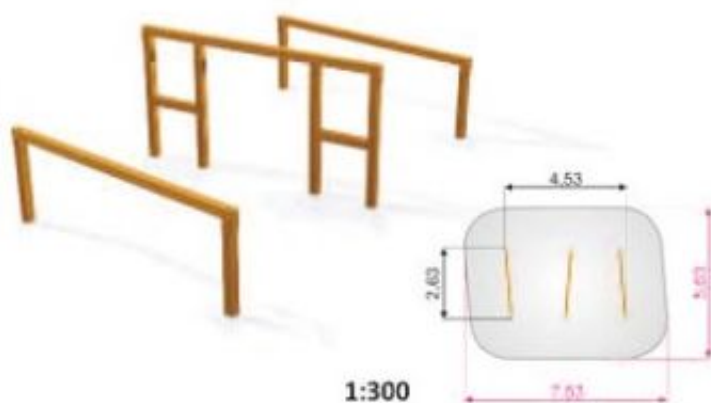

10832 SIT-UPS BENCH



0,87 m 0,87 m 4 h



10837 STUMPS (3 PCS.)

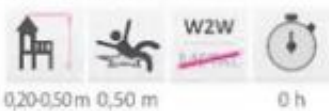

0,20-0,50 m 0,50 m 0 h



10693 BALANCE



0,55 m 0,55 m 3,5 h

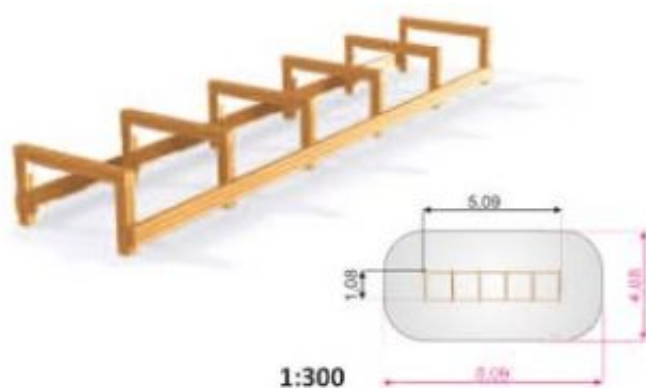
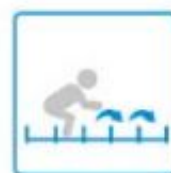

OUTDOOR FITNESS



SENIOR FITNESS

10675 TRAINING TWIST



2,33 m 0,12 m 4 h

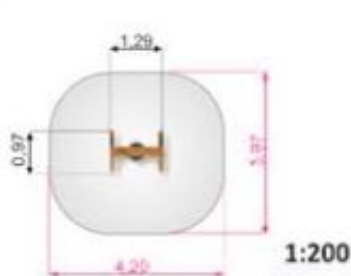

1:200



10677 TRAINING TWIST & SIT



1,26 m 1,12 m 2,5 h

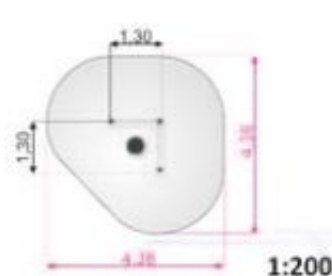

1:200



10672 GYMNASTIC BENCH



0,58 m 0,58 m 1,5 h

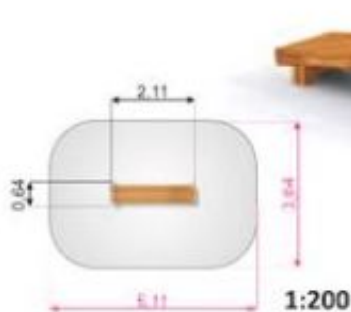

1:200



10899 SOMERSAULT SINGLE

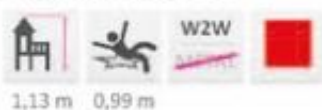

1,13 m 0,99 m 1,5 h

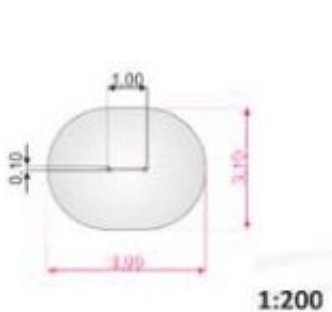

1:200



10900 SOMERSAULT DOUBLE



1,13 m 0,99 m 2 h

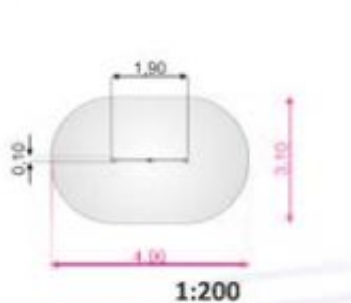

1:200



10901 SOMERSAULT TRIPLE



1,53 m 1,40 m 2,5 h

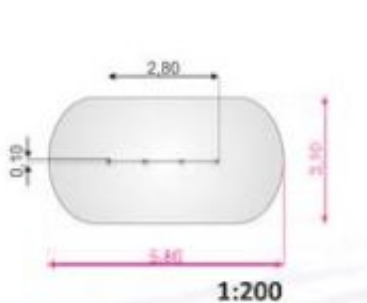

1:200



10679
BRIDGE

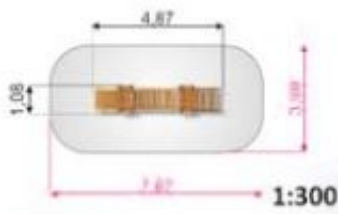
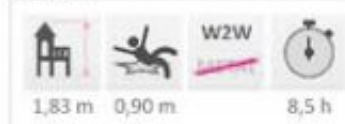

10680
TRAP ROCK

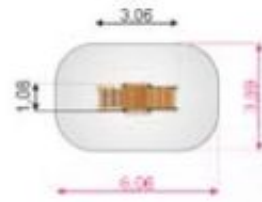
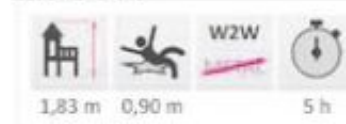

10676
TRAINING RACK

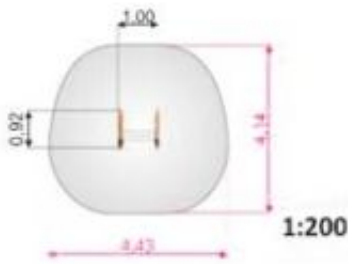

10670
GYMNASTIC BAR, DOUBLE

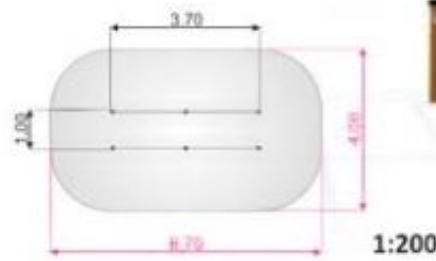

10673
STRETCHING BAR

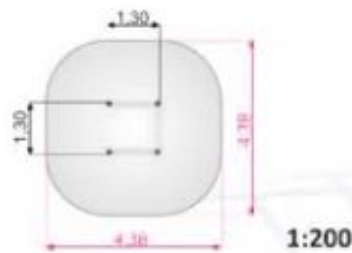

10674
PARALLEL BAR

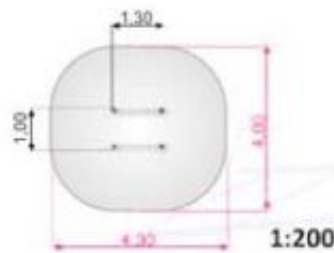

10658
BALANCE



10659
BALANCE

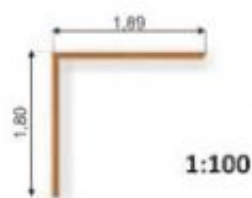

16100 NEW AGE FIT



3,76 m 24 h

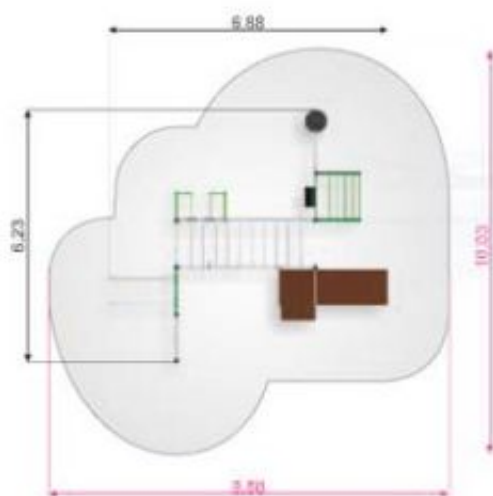

1:200



16101 NEW AGE FIT MEDIUM



3,16 m 22 h

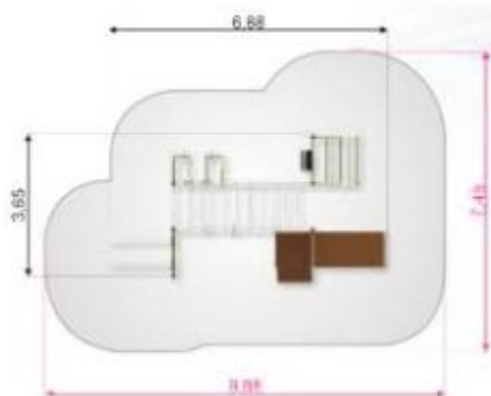

1:200





OUTDOOR FITNESS



METAL FITNESS

16040 AIR WALKER



16042 ROWER



16043 CROSS TRAINER



16041 RIDER



16045 LEG RAISE

A: 0,54 m
B: 1,59 m

2 h



16044 STRETCHING TRIANGLE

A: 0,81 m
B: 0,93 m

1,5 h



16046 DOUBLE BENCH

A: 1,01 m
B: 1,56 m

2,5 h



16050 LEG PRESS

A: 0,50 m
B: 1,10 m

2 h



16051 DOUBLE LEG PRESS

A: 0,50 m
B: 1,98 m

2,5 h



16049 TWISTER

A: 1,40 m
B: 1,60 m

3,5 h



16048 TWISTER + SKI TRAINER

A: 0,90 m
B: 1,31 m

2,5 h



16058 TAI-CHI SMALL WHEELS

A: 0,81 m
B: 1,14 m

2 h



16047 DOUBLE SKI TRAINER

A: 0,90 m
B: 1,15 m

2 h



16057 TAI-CHI BIG WHEELS

A: 0,70 m
B: 0,75 m

2 h



16059 TAI-CHI

A: 0,78 m
B: 1,01 m

2 h



16052 PULL DOWN

A: 0,80 m
B: 1,08 m

2 h



16053 DOUBLE PULL DOWN

A: 0,80 m
B: 1,95 m

2,5 h



16054 CHEST PRESS

A: 0,60 m
B: 0,90 m

2 h



16055 DOUBLE CHEST PRESS

A: 0,60 m
B: 1,58 m

2,5 h



16056 PULL DOWN + CHEST PRESS

A: 0,80 m
B: 1,76 m

2,5 h



16060 INFORMATION BOARD

A: 0,76 m
B: 0,06 m

2,5 h



16030

SET 1



A: 3,82 m
B: 0,84 m

2,5 h

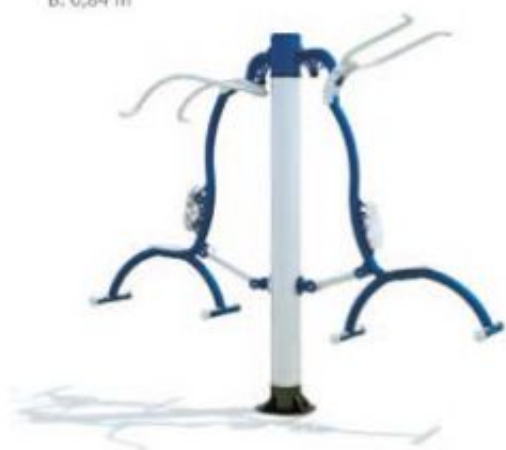

16031

SET 2



A: 1,64 m
B: 0,80 m

2,5 h



16032

SET 3



A: 1,81 m
B: 0,89 m



2,5 h



16033

SET 4



A: 3,47 m
B: 0,94 m



2,5 h



16034
SET 5



A: 1,49 m
B: 1,50 m



16035
SET 6



A: 1,27 m
B: 1,12 m



2,5 h



16037
SET 8



A: 2,95 m
B: 0,65 m



2,5 h

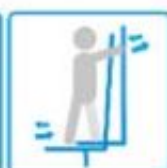

16036
SET 7



A: 2,10 m
B: 1,20 m



2,5 h



OUTDOOR FURNITURE



14210-1
KYOTO
(exotic wood)



A: 0,50 m 0,50 m 0,50 m
B: 2,00 m



1:100



14210-2
KYOTO
(larch)

14211-1
KYOTO SOFFA
(exotic wood)



A: 0,70 m 0,95 m 0,52 m
B: 2,00 m



1:100



14211-2
KYOTO SOFFA
(larch)



14212-1
KYOTO TABLE
(exotic wood)



A: 0,73 m 0,75 m
B: 2,00 m



1:100



14212-2
KYOTO TABLE
(larch)

14222

WIKA



A: 0,45 m 0,45 m 300 kg 0,45 m
B: 1,90 m



14225

LIBRA



A: 0,80 m 0,70 m 317 kg 0,45 m
B: 1,10 m



14229-1

SOFA WAVE
(exotic wood)



A: 0,82 m 0,80 m 0,45 m
B: 2,00 m

14229-2

SOFA WAVE
(larch)



14227-1

TOKYO
(exotic wood)



A: 0,48 m 0,44 m 0,44 m
B: 1,80 m

14227-2

TOKYO
(larch)



13345

CUBE



A: 0,40 m 0,40 m 0,40 m
B: 1,20 m



14343

MARSEILLE DECK CHAIR



A: 0,60 m 0,75 m
B: 1,85 m



14344

MONTPELLIER DECK CHAIR



A: 1,20 m 0,75 m
B: 1,85 m



14341

CANNES DECK CHAIR



A: 0,63 m 0,78 m
B: 1,64 m



14342

SAINT-TROPEZ DECK CHAIR



A: 0,68 m 0,90 m
B: 1,90 m



14340

BREMA BENCH



A: 0,45 m 0,45 m 150 kg 0,45 m
B: 1,80 m



14339

BREMA BENCH W/ BACKREST



A: 0,45 m 0,85 m 170 kg 0,45 m
B: 1,80 m



14335

MALAGA BENCH



A: 0,48 m 0,74 m 0,42 m
B: 1,50 m



14336

MALAGA BENCH w/ ARMREST



A: 0,48 m 0,74 m 0,42 m
B: 1,50 m



14337

MALAGA TABLE w/ SHELF



A: 0,60 m 0,75 m
B: 1,50 m



14338

MALAGA TABLE



A: 0,70 m 0,78 m
B: 1,80 m



14355

MALAGA BIN



A: 0,42 m 1,10 m
B: 0,42 m



14406

VIENNA



A: 0,40 m 0,95 m
B: 0,47 m



14311

VIENNA



A: 0,50 m 0,71 m 0,39 m
B: 1,80 m



14302

LONDON



A: 0,50 m 0,75 m 0,45 m
B: 1,80 m



14310

CITY I



A: 0,50 m 0,77 m 0,43 m
B: 1,80 m



14319

FLORENCE



A: 0,50 m 0,85 m 0,42 m
B: 1,50 m



14330

PARIS



A: 0,37 m 0,41 m 0,41 m
B: 1,80 m



14318

BARCELONA



A: 0,50 m 0,79 m 0,41 m
B: 1,50 m



14401

PRAGUE



A: 0,38 m 0,85 m
B: 0,38 m



14353

PALERMO BIN



A: 0,38 m 0,60 m
B: 0,38 m



14303

BERLIN



A: 0,50 m 0,78 m 0,43 m
B: 1,80 m



14327

PORTO



A: 0,40 m 0,45 m 0,45 m
B: 1,80 m



14309

SOPOT W/BACK



A: 0,60 m 0,68 m 0,43 m
B: 1,80 m



14300

CITY



A: 0,45 m 0,72 m 0,41 m
B: 1,80 m



14329

SOPOT W/O BACK



A: 0,58 m 0,42 m 0,42 m
B: 1,80 m



14328

CITY W/O BACK



A: 0,56 m 0,42 m 0,42 m
B: 1,80 m



14417

SOFIA BIN



A: 0,46 m 0,70 m
B: 0,46 m



14409

CITY BIN



A: 0,28 m 1,00 m
B: 0,28 m



14412

LITTER BIN



A: 0,30 m 0,85 m
B: 0,40 m



14301

CITY II



A: 0,48 m 0,77 m 0,45 m
B: 1,80 m



14312

COPENHAGEN I



A: 0,45 m 0,80 m 0,44 m
B: 1,80 m



14313

COPENHAGEN II



A: 0,50 m 0,85 m 0,44 m
B: 1,80 m



14314

LISBON



A: 0,48 m 0,95 m 0,45 m
B: 1,80 m



14316

COPENHAGEN W/O BACK



A: 0,55 m 0,44 m 0,45 m
B: 1,80 m



14315

LISBON W/O BAC



A: 0,40 m 0,45 m 0,45 m
B: 1,80 m



14414

CITY BIN II



A: 0,35 m 1,10 m
B: 0,42 m



14400

VILNIUS



A: 0,38 m 0,85 m
B: 0,38 m



14321
MONACO



A: 0,60 m 0,85 m 0,44 m
B: 1,80 m



14323
OSLO



A: 0,50 m 0,80 m 0,45 m
B: 1,80 m



14325
DUBLIN



A: 0,55 m 0,85 m 0,44 m
B: 1,80 m



14324
VALENCIA



A: 0,52 m 0,85 m 0,45 m
B: 1,80 m



14326
NICE



A: 0,40 m 0,80 m 0,44 m
B: 1,80 m



14322
MONACO W/O BACK



A: 0,45 m 0,45 m 0,45 m
B: 1,80 m



14413
PARK BIN



A: 0,35 m 1,00 m
B: 0,42 m



14407
ANDORA (WITH ASHTRAY)



A: 0,35 m 0,80 m
B: 0,35 m



14140

BENCH, STEEL CONSTRUCTION



A: 0,50 m 0,77 m 0,43 m
B: 1,80 m



1:200 

14141

BENCH, STEEL CONSTRUCTION



A: 0,80 m 0,77 m 0,43 m
B: 1,80 m



1:200 

14142

TABLE, STEEL CONSTRUCTION



A: 0,71 m 0,71 m
B: 1,80 m



1:200 

14139

BENCH, STEEL CONSTRUCTION



A: 0,28 m 0,43 m 0,43 m
B: 1,80 m



1:200 

14100

LARCHWOOD BENCH



A: 0,55 m 0,78 m 0,40 m
B: 1,80 m



1:200 

14154

BENCH, STEEL CONSTRUCTION



A: 0,53 m 0,75 m 0,43 m
B: 2,13 m



1:200 

14104

LARCHWOOD TABLE & BENCH



A: 1,60 m 0,71 m 0,44 m
B: 1,80 m



1:200

14105

LARCHWOOD TABLE & BENCH FOR KIDS



A: 1,60 m 0,52 m 0,30 m
B: 1,80 m



1:200

14146

TABLE & BENCH STEEL CONSTRUCTION



A: 1,54 m 0,71 m 0,43 m
B: 1,80 m



1:200



14144

TABLE & BENCH STEEL CONSTRUCTION



A: 1,80 m 0,77 m 0,43 m
B: 1,84 m



1:200



14147

QUADRO TABLE AND BENCH



A: 2,35 m 0,77 m 0,43 m
B: 2,35 m



1:200



14148

TABLE & BENCH WITH 6 SEATS



A: 3,31 m 0,77 m 0,43 m
B: 3,34 m



1:200



14150

SCHOOL TABLE AND BENCH



A: 3,33 m 0,77 m 0,43 m
B: 3,39 m



1:200



14152

OCTAGONAL TREE BENCH



A: 2,31 m 0,43 m 0,43 m
B: 2,31 m



1:200



14435

TORONTO BENCH



A: 0,55 m 0,60 m 0,45 m
B: 2,04 m



14415

TORONTO BIN



A: 0,47 m 0,93 m
B: 0,58 m



14563

TORONTO FLOWERPOT



A: 0,55 m 0,61 m
B: 1,08 m



14437

SYDNEY BENCH



A: 0,55 m 0,80 m 0,45 m
B: 2,25 m



14418

SYDNEY BIN



A: 0,39 m 1,05 m
B: 0,51 m



14567

SYDNEY FLOWERPOT



A: 0,59 m 0,60 m
B: 1,17 m



14440

ZURICH BENCH



A: 0,70 m 0,81 m 0,45 m
B: 1,82 m



14421

BARI BIN



A: 0,30 m 1,00 m
B: 0,30 m



14570

ZURICH FLOWERPOT



A: 0,30 m 0,40 m
B: 0,30 m



14436

UPPSALA BENCH



A: 0,60 m 0,85 m 0,46 m
B: 1,92 m



14416

UPPSALA BIN



A: 0,37 m 0,90 m
B: 0,48 m



14564

UPPSALA FLOWERPOT



A: 0,80 m 0,74 m
B: 0,80 m



14438

CHICAGO BENCH



A: 0,58 m 0,80 m 0,43 m
B: 2,02 m



14419

CHICAGO BIN



A: 0,43 m 0,80 m
B: 0,46 m



14568

CHICAGO FLOWERPOT



A: 0,58 m 0,45 m
- 0,39 m
B: 1,17 m



14439

OXFORD BENCH



A: 0,60 m 0,85 m 0,43 m
B: 1,90 m



14420

OXFORD BIN



A: 0,41 m 1,02 m
B: 0,45 m



14569

OXFORD FLOWERPOT



A: 0,59 m 0,69 m
B: 1,17 m



18100

TALLIN BENCH W/O BACKREST



A: 0,50 m 0,45 m 0,45 m
B: 1,80 m



18104

RYGA BENCH W/O BACKREST



A: 0,50 m 0,45 m 0,45 m
B: 1,80 m



18101

TALLIN BENCH W/ ARMRESTS



A: 0,55 m 0,60 m 0,45 m
B: 1,80 m



18105

RYGA BENCH W/ ARMRESTS



A: 0,55 m 0,60 m 0,45 m
B: 1,80 m



18102

TALLIN BENCH W/ BACKREST



A: 0,53 m 0,88 m 0,45 m
B: 1,80 m



18106

RYGA BENCH W/ BACKREST



A: 0,60 m 0,88 m 0,45 m
B: 1,80 m



18103

TALLIN BENCH



A: 0,53 m 0,88 m 0,45 m
B: 1,80 m



18107

RYGA BENCH



A: 0,60 m 0,88 m 0,45 m
B: 1,80 m



18108

RYGA DECO BENCH



A: 0,60 m 0,45 m 0,45 m
B: 1,80 m



18109

RYGA DECO BENCH W/ BACKREST



A: 0,66 m 0,77 m 0,45 m
B: 1,80 m



18110

TALLIN DOUBLE BENCH



A: 0,73 m 0,45 m 0,45 m
B: 1,47 m



18111

RYGA TABLE



A: 0,76 m 0,76 m
B: 1,80 m



14354

TALLIN BIN



A: 0,38 m 0,82 m
B: 0,38 m



14350

RYGA BIN LIGHT

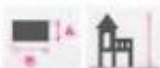

A: 0,38 m 0,66 m
B: 0,42 m



14356

RYGA FLOWERPOT LIGHT



A: 0,58 m 0,67 m
B: 0,94 m



14351

RYGA BIN DARK



A: 0,38 m 0,66 m
B: 0,42 m



14357

RYGA FLOWERPOT DARK



A: 0,58 m 0,67 m
B: 0,94 m



14740

RYGA BIKE STAND



A: 0,08 m 0,75 m
B: 0,85 m



14223
GENEVA V



A: 0,39 m 0,45 m 125 kg 0,45 m
B: 2,10 m



14538
GENEVA IV



A: 0,39 m 0,45 m 169 kg
B: 1,17 m



14404
GENEVA (ROUND)



A: 0,48 m 0,60 m 103 kg
B: 0,48 m



14537
GENEVA III



A: 0,78 m 0,60 m 192 kg
B: 0,78 m



14403
GENEVA



A: 0,39 m 0,60 m 105 kg
B: 0,39 m



14228
DONA



A: 0,57 m 0,82 m 270 kg 0,43 m
B: 2,00 m



14220
VEGA



A: 0,40 m 0,47 m 300 kg 0,47 m
B: 1,90 m



14221
VEGA DECO



A: 0,40 m 0,47 m 300 kg 0,47 m
B: 1,90 m



17163
LOUNGE TABLE



0,35 m



17162
LOUNGE TABLE



0,12 m



17160
LOUNGE CHAIR



0,67 m 0,33 m

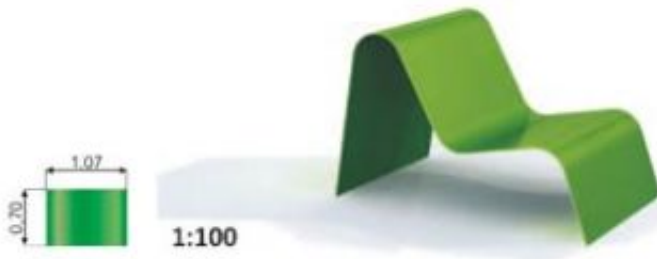

17161
LOUNGE SOFA



0,67 m 0,26 m

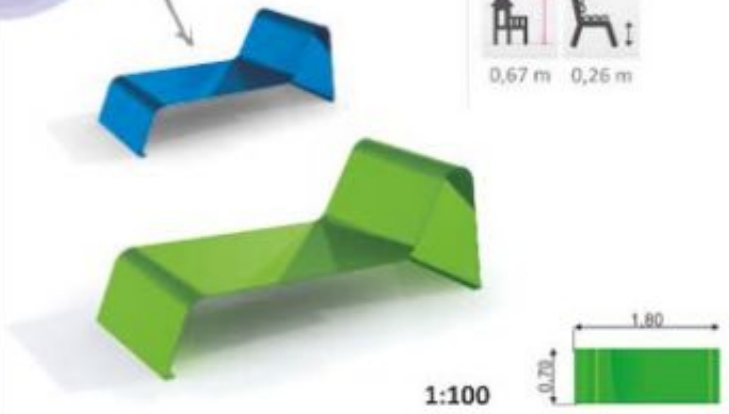

14453 HPL BENCH



A: 0,48 m 0,73 m 0,41 m
B: 1,80 m



1:100



14454 HPL BENCH FREESTANDING



A: 0,80 m 0,73 m 0,41 m
B: 1,80 m



1:100



14450 KYOTO TABLE HPL



A: 0,73 m 0,75 m
B: 2,00 m



1:100

14460 TABLE HPL



A: 0,75 m 0,69 m
B: 1,80 m



1:100



14451 KYOTO BENCH HPL



A: 0,50 m 0,46 m 0,46 m
B: 2,00 m



1:100

14452 KYOTO SOFA HPL



A: 0,70 m 0,95 m 0,41 m
B: 2,00 m

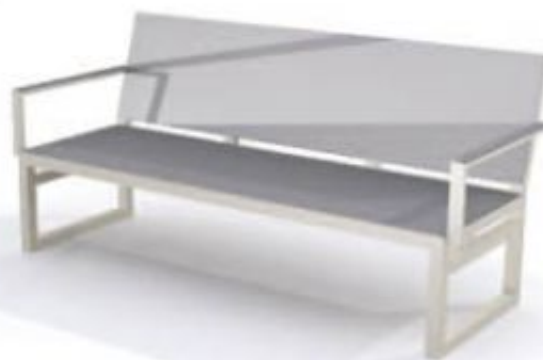

1:100

14455

TABLE & BENCH HPL



A: 1,54 m 0,69 m 0,41 m
B: 1,80 m



1:200

14461

TABLE & BENCH HPL FOR KIDS



A: 1,54 m 0,52 m 0,31 m
B: 1,20 m



1:200

14456

TABLE & BENCH HPL



A: 1,84 m 0,73 m 0,41 m
B: 1,80 m



1:200

14462

TABLE & BENCH HPL FOR KIDS



A: 1,84 m 0,63 m 0,31 m
B: 1,20 m



1:200

14457

TABLE & BENCH QUADRO HPL



A: 2,35 m 0,73 m 0,41 m
B: 2,35 m



1:200

14458

TABLE & BENCH 6 SEATS HPL



A: 3,13 m 0,73 m 0,41 m
B: 3,19 m



1:200

11586

SHELTER WITH TABLE



A: 1,75 m 2,18 m 0,56 m
B: 3,51 m



1:200

14459

SCHOOL TABLE AND BENCH HPL



A: 3,33 m 0,73 m 0,41 m
B: 3,39 m



1:200

14562

GLOBE

A: 0,60 m
B: 0,60 m

0,54 m

102 kg



14560

FOSSANO

A: 1,46 m
B: 1,46 m

0,42 m

300 kg



14528

ROSALY

A: 0,50 m
B: 0,50 m

0,50 m

130 kg



14529

BERTA

A: 1,00 m
B: 1,00 m

0,60 m

889 kg



14530

MILANO

A: 0,40 m
B: 1,20 m

0,40 m

250 kg



14531

ALEX

A: 0,70 m
B: 0,81 m

0,53 m

230 kg



14561

BELL

A: 0,46 m
B: 0,46 m

0,26 m

33 kg



14585

WOODEN FLOWERPOT I



A: 0,40 m 0,32 m
B: 0,40 m



14586

WOODEN FLOWERPOT II



A: 0,36 m 0,32 m
B: 0,84 m



14587

WOODEN FLOWERPOT III



A: 0,43 m 0,32 m
B: 0,50 m



14588

WOODEN FLOWERPOT IV



A: 0,58 m 0,32 m
B: 0,67 m



14589

FLOWERPOT MAXI



A: 1,00 m 0,27 m
B: 1,00 m



14581

PALERMO FLOWERPOT



A: 0,71 m 0,57 m
B: 0,71 m



14600

GRILL



A: 0,60 m 0,58 m
B: 0,76 m



14603

YUKON



A: 0,09 m 2,06 m
B: 1,19 m



14604

PARANA



A: 0,09 m 1,06 m
B: 0,97 m



14602

KEMI



A: 0,60 m 2,50 m
B: 1,15 m



14605

RULES TAB



A: 0,14 m 2,16 m
B: 1,00 m





14755
BIKE PARKING I



A: 2,19 m 2,10 m
B: 4,10 m



1:100



14756
BIKE PARKING I



A: 2,00 m 2,19 m
B: 4,10 m

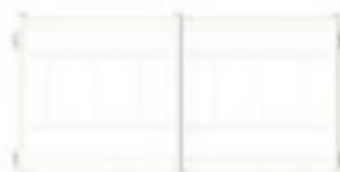

1:100



14757
BIKE PARKING I



A: 2,00 m 2,16 m
B: 4,10 m

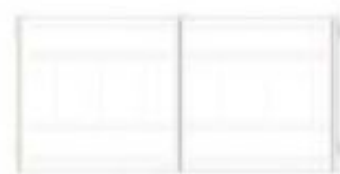

1:100

14731 CLASSIC II



A: 0,22 m 0,55 m
B: 3,00 m



14732 CLASSIC III



A: 0,39 m 0,55 m
B: 3,00 m



14730 CLASSIC V



A: 0,50 m 0,80 m
B: 2,50 m



14730-1 CLASSIC X



A: 0,65 m 0,80 m
B: 2,50 m



14745 BIKE STAND



A: 0,31 m 0,55 m
B: 1,78 m



14743 BIKE STAND



A: 0,09 m 1,06 m
B: 0,97 m



14736 BIKE PARKING II



A: 0,27 m 0,31 m
B: 1,48 m



14737 BIKE PARKING III



A: 0,43 m 0,33 m
B: 1,38 m



14733
NEW DESIGN



A: 0,30 m 0,75 m
B: 0,50 m



14735
BIKE PARKING I



A: 0,40 m 0,20 m
B: 1,60 m



14734
PRACTIC



A: 0,04 m 0,75 m
B: 0,85 m



14739
BICYCLE STAND X



A: 0,65 m 0,80 m
B: 2,50 m



14746
BIKE STAND



A: 0,30 m 0,55 m
B: 1,25 m



14744
BIKE STAND



A: 0,63 m 0,55 m
B: 0,63 m



14741
BIKE STAND



A: 0,34 m 0,40 m
B: 1,62 m



14742
BIKE STAND



A: 0,45 m 0,45 m
B: 2,00 m



SUNSHADES



14804
SUN SHADE TRIANGLE 3X3X3 PIONEER (LARCHWOOD)



A: 3,18 m 3,01 m 2 h
B: 3,67 m



14802
SUN SHADE TRIANGLE 3X3X3 NATURE



A: 3,21 m 3,01 m 2 h
B: 3,69 m



14801
SUN SHADE TRIANGLE 3X3X3 ATLANTIS (METAL)



A: 3,16 m 3,01 m 2 h
B: 3,63 m



14821

SUN SHADE SQUARE ATLANTIS (METAL)



A: 5,54 m 3,01 m 2,5 h
B: 5,54 m



14824

SUN SHADE SQUARE PIONEER (LARCHWOOD)



A: 5,58 m 3,01 m 2,5 h
B: 5,58 m



14822

SUN SHADE SQUARE NATURE



A: 5,59 m 3,01 m 2,5 h
B: 5,59 m



SAFETY SURFACES



RUBBER SAFETY MATS

Number	Dimensions	Thickness	Critical fall height
15124	1,5 x 1 m	22 mm	up to 2,7 m



Rubber mats can be installed directly on loose surfaces like sand or gravel. The holes allow the grass to grow up through the mats and thereby create a green area.

The safetymats are suitable for both sport and play areas.

The standard colour of rubber mats is black.

The basic dimension of rubber mats is 100x150 cm.

ARTIFICIAL GRASS

Lars Laj Proplay system consists of impact mats, covered with artificial grass, providing a safe, clean and dry play surface for children.

Proplay mats are produced in a unique process from high quality polyethylene foam, having closed cells. Owing to this, it is possible to receive mats of high durability, simultaneously preserving high flexibility.

Dependingly on the required degree of impact absorption, Proplay mat consists of one or two layers, covered with artificial grass. The standard finishing colour is green, however other colours are available upon request. The use of Proplay mats enables drainage, both vertical and horizontal. Proplay mats can be laid on most types of base and they will follow the contours of that base without cracking or any other damage.

Proplay mats are simple to install. They are produced with interconnecting joints, allowing to connect them together. Artificial grass can be simply laid on a layer of polyethylene foam and filled with crumb, sand or the mixture of both. Proplay mat can be easily cut to size, using a sharp knife.

Proplay mats are available in a wide assortment of dimensions.



Article No	Critical fall height
15313 Proplay 25	1,3 m
15316 Proplay 35	1,7 m
15325 Proplay 45	2,1 m
15330 Proplay 70	2,7 m
MultiSport Proplay PP20	-



RUBBER TILES



Rubber tiles are produced from coloured rubber granulate with grain size of 1-3 mm, connected with polyurethane glue.

The combination of those components gives as a result a safety surface of high impact absorption properties.

Not many other types of safe surface have as many advantages as the rubber tile surface. Some of the advantages of such a surface are: minimized risk of injury owing to excellent impact absorption properties, ease of keeping surface in a good technical condition, easy installation, perfect antislip and sound absorbing properties, high humidity resistance, accordance with requirements

of the norm EN 1177.

Rubber tiles can be laid on tarmac, concrete or any other type of stabilized base and joined together with a system of connectors.

As rubber tiles do not crack, you can be sure that they will last for a very long time.

Standard colors: red-brown.

Available upon request in:

- grey • green • silver-grey • blue • black

Article No	Thickness	Critical fall height
15025	25 mm	-
15030	30 mm	1,0
15035	35 mm	1,3
15045	45 mm	1,5
15055	55 mm	1,9
15070	70 mm	2,2
15090	90 mm	2,8
15100	100 mm	3,1

WETPOUR



Wetpour is one of the best and nicest surfaces for indoor and outdoor. It can be installed directly onto hard surfaces like tarmac with ramped edges. Lars Laj is able to supply wetpour surfaces in a variety of colours according to our customers requirements.

Wetpour consists of two layers: bottom layer made of black SBR granulate and top layer made of coloured rubber EPDM granulate. The task of the bottom layer is to absorb the impact energy. Top layer is UV resistant and its task is to protect the bottom layer against wiping off.

Synthetic mass is a combination of granulate with polyurethane glue in proper proportions. Mixing of granulate with glue is done in the drum mixer.

The installation of wetpour begins with pouring layer of black granulate. Toughening time of the layer is 24 hours. The next stage of the installation is toughening the surface with a metal roll, and afterwards covering it with a layer of polyurethane glue. After 2 hours from application of polyurethane glue, the top layer of coloured granulate can be spread. Toughening of the layer of coloured rubber mass is done with a metal roll after 24 hours from pouring it.

PLAYGROUNDS* SURFACE - SBR+EPDM		
Article No	Thickness	Critical fall height
15230	40 mm (30+10)	1,2
15245	50 mm (40+10)	1,4
15270	60 mm (50+10)	1,7
15299	70 mm (60+10)	1,8
15230	80 mm (70+10)	2,2
15245	90 mm (80+10)	2,3
15270	110 mm (100+10)	2,6
15299	120 mm (110+10)	2,6

*To get the offer on SPORT SURFACE contact our sales office.









LARS LAJ®

Lars Laj AS

Kildebrøndevej 48 • 2670 Greve • Denmark

tel. + 45 32 82 10 33

www.larslaj.com • larslaj@larslaj.com